







Hoval TopVent[®] gas TG | GV | MG

Design handbook

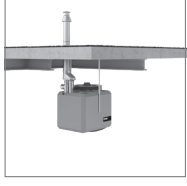
Recirculation units and supply air units with efficient air distribution
for heating with gas-fired heat exchanger

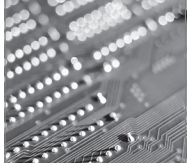

	<p>Hoval Indoor Climate Systems 3</p> <p>Efficient. Flexible. Reliable.</p>	<p>A</p>
	<p>TopVent® TG 7</p> <p>Recirculation units with efficient air distribution for heating spaces up to 25 m in height with gas-fired heat exchanger</p>	<p>B</p>
	<p>TopVent® GV 19</p> <p>Recirculation units for heating spaces up to 6 m in height with gas-fired heat exchanger</p>	<p>C</p>
	<p>TopVent® MG 31</p> <p>Recirculation units with efficient air distribution for ventilation and heating of spaces up to 25 m in height with gas-fired heat exchanger</p>	<p>D</p>
	<p>Options 43</p>	<p>E</p>
	<p>Transport and installation 51</p>	<p>F</p>
	<p>System design 61</p>	<p>G</p>
	<p>Control systems</p> <p>Hoval TopTronic® C → see 'Control Systems for Hoval Indoor Climate Systems' manual</p>	<p></p>



Hoval Indoor Climate Systems

Efficient. Flexible. Reliable.

A



Efficient. Flexible. Reliable.

Hoval indoor climate systems are decentralised systems for heating, cooling and ventilating halls for industrial, commercial and leisure applications. The systems have a modular structure. One system comprises several ventilation units which are spread around the room. These units are equipped with reversible heat pumps and gas-fired appliances for decentralised heat and cold generation, or they heat and cool with a connection to a central energy supply. Tailored control systems complete the system and ensure the effective combination and optimal use of all resources.

Diverse range of units ensures flexibility

Different types of ventilation units can be combined to create the perfect system for the project in question:

- RoofVent® supply and extract air handling units
- TopVent® supply air units
- TopVent® recirculation units

The number of supply and extract air handling units depends on how much fresh air is required in order to create a comfortable atmosphere for people in the building. Recirculation units cover additional heat or cool demand as required. A broad range of unit types and sizes with heating and cooling coils in various output levels means that the overall output of the system can be scaled to whatever level is required.

Specially designed unit versions are also available for halls with particularly humid or oily extract air.

Furthermore, there is a range of units available which have been expressly developed for very specific purposes. ProcessVent units, for example, are coupled with extract air purification systems in industrial halls and recover heat from process air.

Draught-free air distribution

A key feature of Hoval indoor climate units is the patented vortex air distributor, known as the Air-Injector. It is controlled automatically and changes the blowing angle of the air continuously between vertical and horizontal. The highly efficient air supply system has many advantages:

- It provides a high level of comfort during heating and cooling. No draughts develop in the hall.
- The efficient and even air distribution ensures that the indoor climate units cover a large area.
- The Air-Injector keeps the temperature stratification in the room low, thus minimising heat loss through the roof.

Control with specialist expertise

The TopTronic® C control system, which was specifically developed for Hoval indoor climate systems, regulates the separate units individually and controls them based on zones. This enables optimal adjustment to the local requirements of the different usage areas in the building. The patented control algorithm optimises energy use and ensures maximum comfort and hygiene levels. Clear interfaces make it easy to connect the system to the building management system.

Simpler control systems are also available for units that are only used for supply air or air recirculation.

Competent and reliable

Hoval will support you and provide expert knowledge throughout all project phases. You can rely on comprehensive technical advice when it comes to planning Hoval indoor climate systems and on the skills of the Hoval technicians during the installation, commissioning and maintenance of the system.

System with decentralised heat and cold generation with heat pump

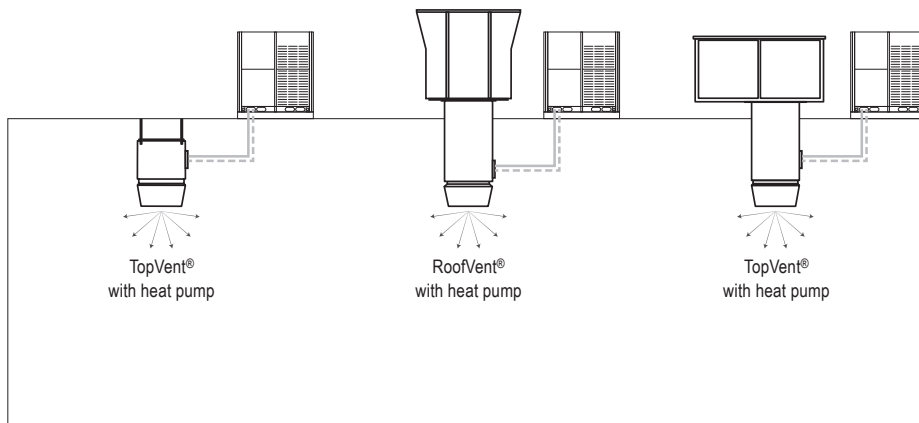

System with central heat and cold generation

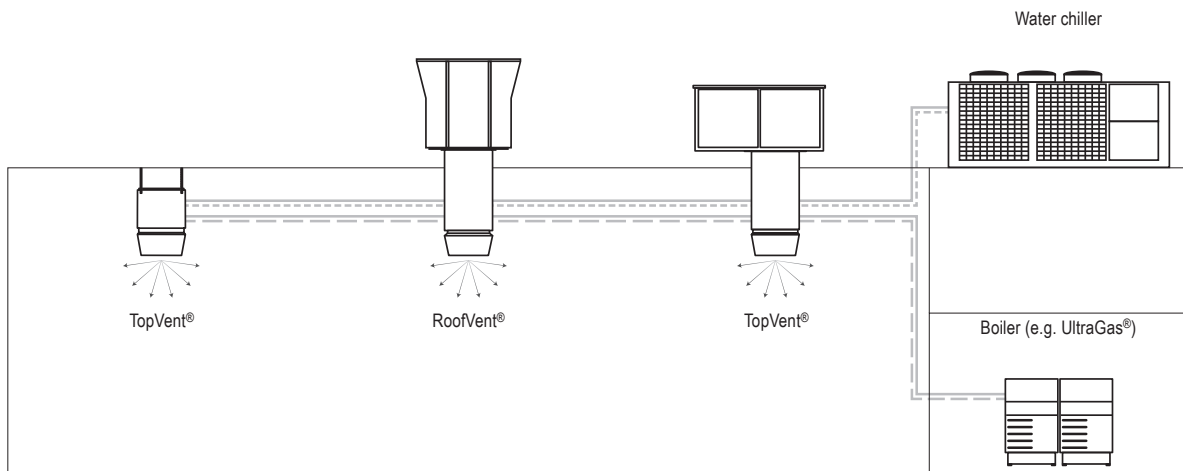

System with decentralised, gas-fired heat generation

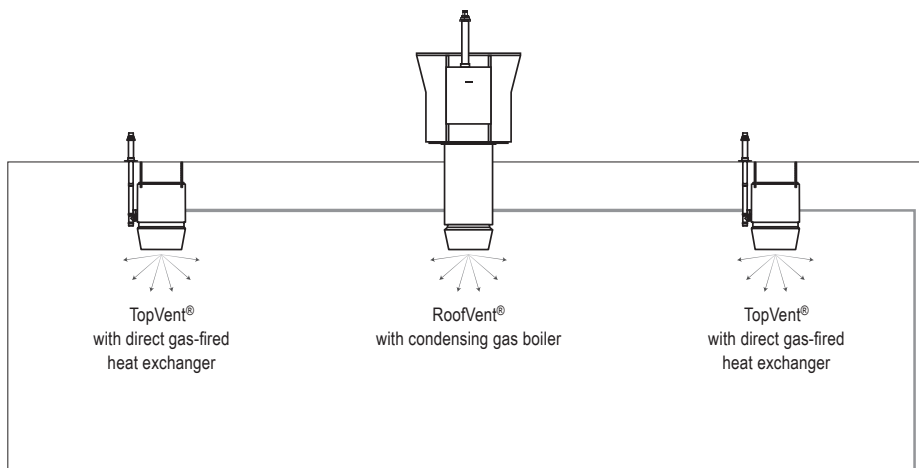



TopVent® TG

Recirculation units with efficient air distribution
for heating spaces up to 25 m in height
with gas-fired heat exchanger

1 Use 8

2 Construction and operation 8

3 Technical data 11

4 Dimensions and weights. 13

5 Specification texts 14

B

1 Use

1.1 Intended use

TopVent® TG units are recirculation units for heating spaces up to 25 m in height with gas-fired heat exchanger. They have the following functions:

- Heating with gas-fired heat exchanger
- Recirculation operation
- Air distribution and destratification with adjustable Air-Injector
- Air filtration (option)

TopVent® TG units comply with all the requirements of the Ecodesign Directive 2009/125/EC relating to environmentally friendly design of energy-related products. They are systems of the 'warm air heater' type, provided for in Commission Regulation (EU) 2016/2281.

The Hoval TopTronic® C integrated control system ensures energy-efficient, demand-based operation of Hoval indoor climate systems.

Intended use also includes compliance with the operating instructions. Any usage over and above this use is considered to be not as intended. The manufacturer can accept no liability for damage resulting from improper use.

1.2 User group

The units are only allowed to be installed, operated and maintained by authorised and instructed personnel who are well acquainted with the units and are informed about possible dangers.

2 Construction and operation

2.1 Construction

The TopVent® TG unit consists of the following components:

- Fan unit:
Axial fan with energy-saving EC motor, maintenance-free and infinitely variable
- Heating section:
The heating section contains the burner unit consisting of gas blower and modulating premix burner, the burner control and the heat exchanger for heating the supply air.
- Air-Injector:
The Air-Injector is a patented, infinitely variable vortex air distributor for the draught-free introduction of air into the hall under changing operating conditions.

As part of the TopTronic® C control system, the unit control box is an integral component.

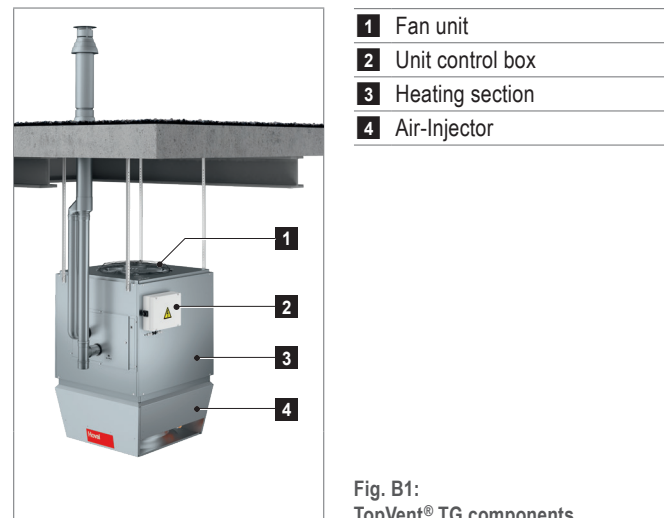
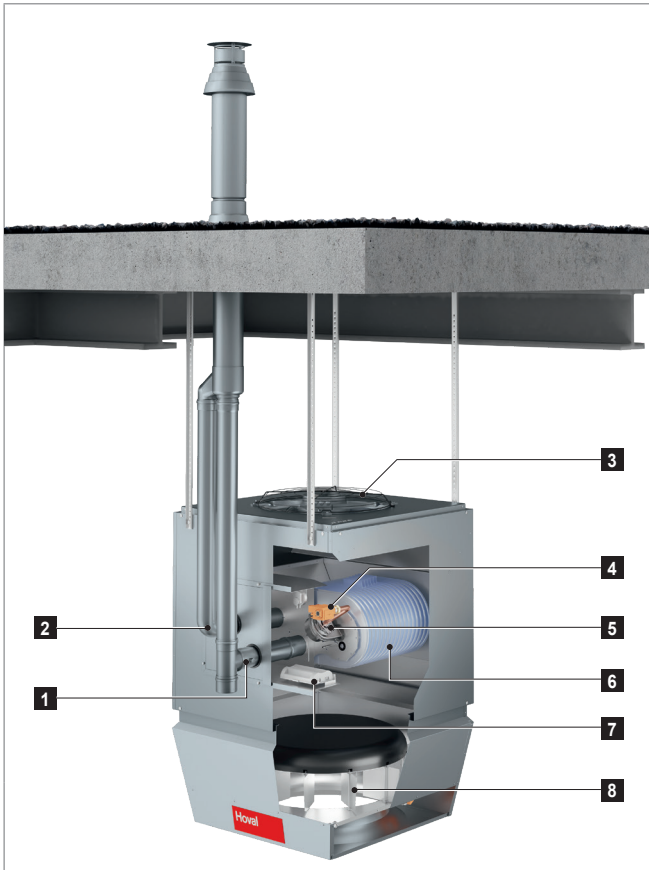

Fig. B1:
TopVent® TG components



- 1** Flue gas connection
- 2** Combustion air connection
- 3** Fan
- 4** Gas control valve and gas connection
- 5** Burner unit consisting of gas blower and premix burner
- 6** Heat exchanger of stainless steel
- 7** Burner control
- 8** Air-Injector

Fig. B2: TopVent® TG construction

2.2 Function diagram

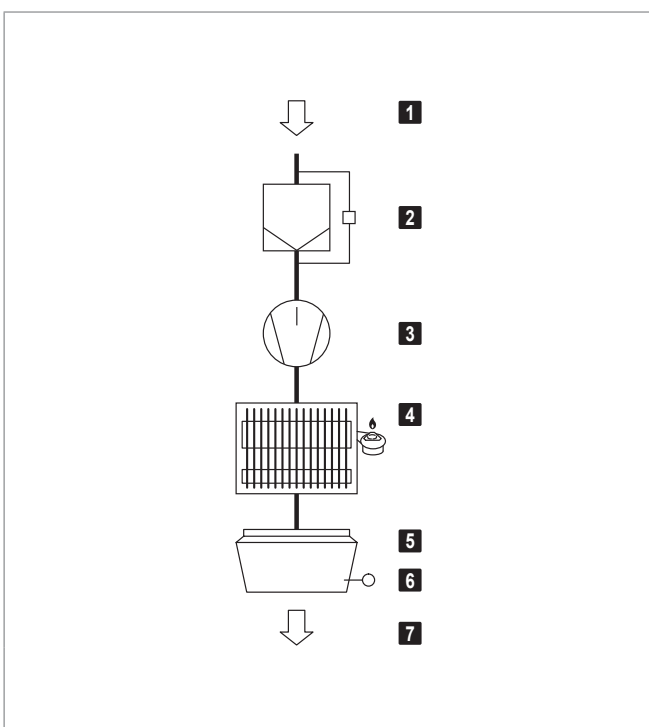

- 1** Extract air
- 2** Air filter with differential pressure switch (option)
- 3** Fan
- 4** Gas-fired heat exchanger
- 5** Air-Injector with actuator
- 6** Supply air temperature sensor
- 7** Supply air

Fig. B3: TopVent® TG function diagram

2.3 Operating modes

TopVent® TG operates in the following modes:

- Recirculation
- Recirculation speed 1
- Standby

The TopTronic® C control system regulates these operating modes automatically for each control zone in accordance with the specifications in the calendar. The following points also apply:

- The operating mode of a control zone can be switched over manually.
- Each TopVent® TG unit can operate individually in a local operating mode: Off, Recirculation, Recirculation speed 1.

Code	Operating mode		Description
REC	Recirculation On/off-operation: If heating is required, the unit draws in room air, heats it and blows it back into the room. The room temperature set value day is active.		Fan speed 1/2 ¹⁾ Heating on ¹⁾ ¹⁾ Depending on heat demand
DES	■ Destratification: To avoid heat build-up under the ceiling, it may be appropriate to switch on the fan when there is no heat demand (either in permanent operation or in on/off operation depending on the temperature stratification, as desired).		Fan speed 2 Heating off
REC1	Recirculation speed 1 The same as REC, but the unit operates only at speed 1 (low air flow rate)		Fan speed 1 ¹⁾ Heating on ¹⁾ ¹⁾ Depending on heat demand
DES	■ Destratification: The same as for REC, but the unit operates only at speed 1		Fan speed 1 Heating off
ST	Standby The unit is ready for operation. The following operating modes are activated if required:		
CPR	■ Cooling protection: If the room temperature drops below the set value for cooling protection, the unit heats up the room in recirculation operation.		Fan speed 2 Heating on
L_OFF	Off (local operating mode) The unit is switched off.		Fan off Heating off

Table B1: TopVent® TG operating modes

3 Technical data

3.1 Type code

TG - 6 F - ...	
Unit type	TopVent® TG
Unit size	6 or 9
Heating section	F with coil type F (output 30 kW) H with coil type H (output 60 kW)
Further options	

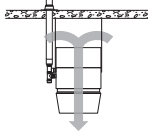
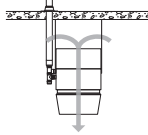
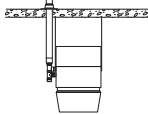
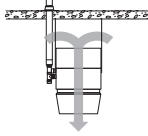
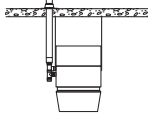
Table B2: TopVent® TG type code

3.2 Application limits

Extract air temperature	max.	°C	50
Supply air temperature	max.	°C	55
Protection rating			IP 50
The units cannot be used in:			
<ul style="list-style-type: none"> ■ Damp locations ■ Places with a corrosive or aggressive environment ■ Spaces with a large amount of dust ■ Areas where there is danger of explosion 			

Table B3: TopVent® TG application limits

3.3 Electrical connection

Unit type		TG-6	TG-9
Supply voltage	V AC	3 x 400	3 x 400
Permitted voltage tolerance	%	± 5	± 5
Frequency	Hz	50	50
Power consumption max.	W	1360	1960
Current consumption max.	A	2.3	3.4
Series fuse	A	13	13
Protection rating of unit control box	–	IP 56	IP 56

Table B4: TopVent® TG electrical connection

3.4 Air flow rate, gas consumption

Unit type		TG-6	TG-9
Nominal air flow rate ¹⁾	m³/h	7000	11000
Minimum air flow rate	m³/h	5000	9000
Floor area covered			
<ul style="list-style-type: none"> ■ for applications with higher comfort requirements (e.g. production halls, assembly halls, sports halls) 	m²	644	1232
<ul style="list-style-type: none"> ■ for applications with low comfort requirements (e.g. warehouses, logistics centres) 	m²	731	1583
Nominal heat input	max. kW	32.0	66.0
Nominal heat output	max. kW	28.9	61.2
Gas consumption			
Natural gas: G20, G27 (H, E, Lw)	m³/h	3.4	7.0
Natural gas: G25, G25.3 (L, LL, K)	m³/h	3.8	7.9

¹⁾ at an air temperature of 20 °C

Table B5: TopVent® TG technical data

3.5 Gas connection

Unit type	TG-6	TG-9
Gas appliance type ¹⁾	B ₂₃ , C ₁₃ , C ₃₃	B ₂₃ , C ₁₃ , C ₃₃
Gas connection	G ½" (internal)	G ¾" (internal)
Combustion air connection	DN 80	DN 80
Flue gas connection	DN 80	DN 80
Max. length of flue gas duct ²⁾	6 m	8 m

¹⁾ according to method of flue gas evacuation and combustion air supply
²⁾ Equivalent length of formed parts:
 – 90° elbow 2 m
 – 45° elbow 1 m
 – 90° T-piece... 2 m

Table B6: TopVent® TG gas circuit connections

3.6 Sound level

Unit type		TG-6	TG-9
Sound pressure level (at a distance of 5 m) ¹⁾	dB(A)	50	54
Total sound power level	dB(A)	72	76
Octave sound power level			
	63 Hz	dB	47
	125 Hz	dB	54
	250 Hz	dB	59
	500 Hz	dB	64
	1000 Hz	dB	68
	2000 Hz	dB	65
	4000 Hz	dB	59
	8000 Hz	dB	52

¹⁾ with a hemispherical radiation pattern in a low-reflection room

Table B7: TopVent® TG sound level

3.7 Heat output

Room air temperature	16 °C			20 °C		
Unit type	Q	t _s	H _{max}	Q	t _s	H _{max}
	kW	°C	m	kW	°C	m
TG-6	28.9	30.3	17.4	28.9	34.3	17.5
TG-9	61.2	34.5	17.1	61.2	38.5	17.2
Legend:	Q = Nominal heat output t _s = Maximum supply air temperature H _{max} = Maximum mounting height					
Reference:	■ At room air temperature 16 °C: extract air temperature 18 °C ■ At room air temperature 20 °C: extract air temperature 22 °C					

Table B8: TopVent® TG heat output, supply air temperatures and mounting heights

3.8 Product information according to ErP

Model	TopVent® TG		Unit	
	TG-6	TG-9		
B ₁ warm air heater	yes			
C ₂ warm air heater	no			
C ₄ warm air heater	no			
Type of fuel	gas			
Capacity	Rated heating capacity (P _{rated,h})	28.9	61.2	kW
	Minimum capacity (P _{min})	17.0	37.9	kW
Useful efficiency	At rated heating capacity (η _{nom})	90.4	92.7	%
	At minimal capacity (η _{pl})	94.6	95.6	%
Electric power consumption	At rated heating capacity (eI _{max})	0.717	0.917	kW
	At minimal capacity (eI _{min})	0.337	0.548	kW
	In standby mode (eI _{sb})	0.034	0.034	kW
Other items	Envelope loss factor (F _{env})	–	–	%
	Ignition burner power consumption (P _{ign})	–	–	kW
	Emissions of nitrogen oxides (GCV) (NO _x)	45	45	mg/kWh
	Emission efficiency (η _{s,flow})	95.1	94.0	%
	Seasonal space heating energy efficiency (η _{s,h})	79.3	79.4	%
Contact details	Hoval Aktiengesellschaft, Austrasse 70, 9490 Vaduz, Liechtenstein www.hoval.com			

Table B9: Product information according to Commission Regulation (EU) 2016/2281, Table 9

4 Dimensions and weights

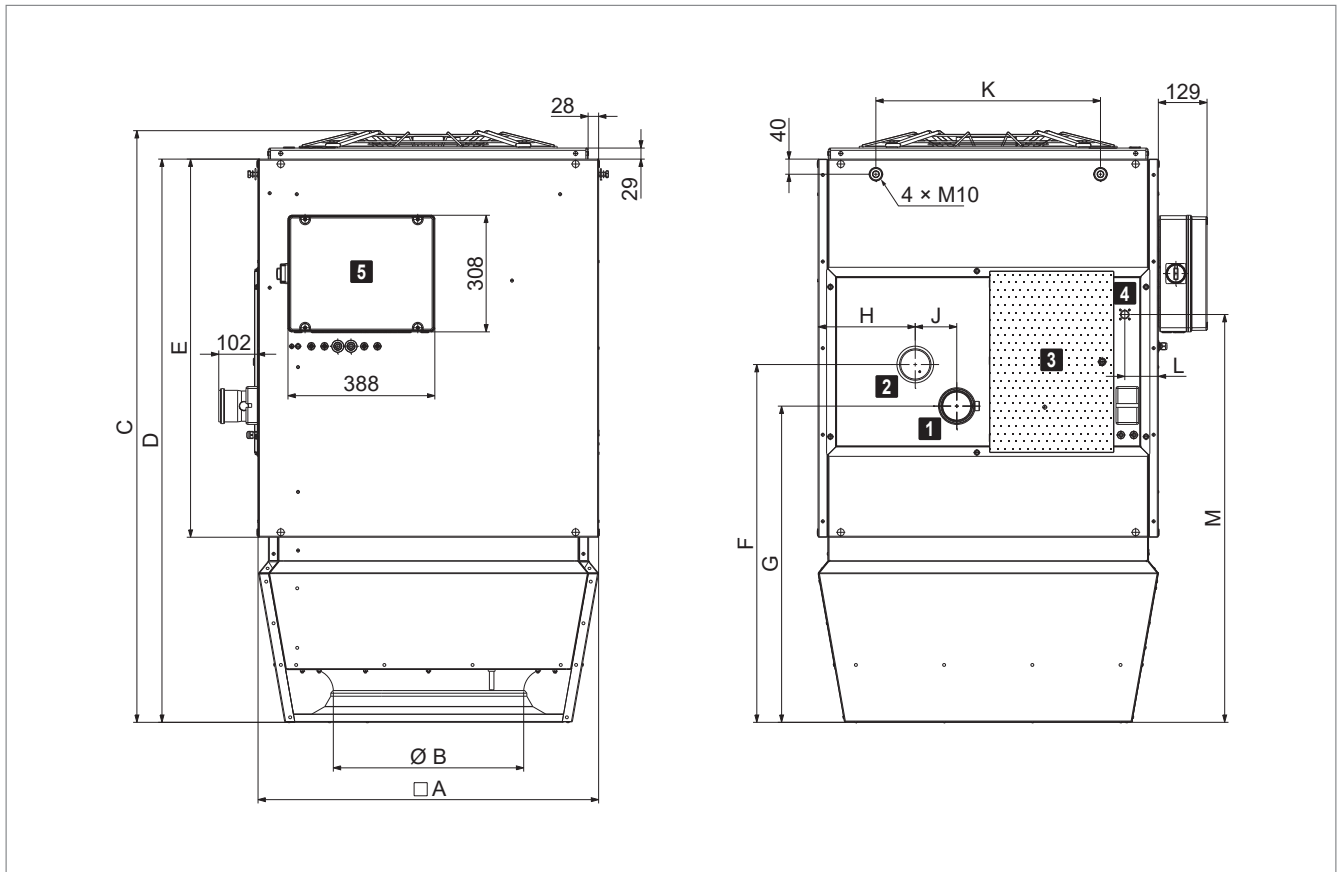

Unit type		TG-6	TG-9
A	mm	900	1100
B	mm	500	630
C	mm	1565	1672
D	mm	1490	1570
E	mm	1000	1000
F	mm	946	1019
G	mm	836	909
H	mm	257	461
J	mm	110	110
K	mm	594	846
L	mm	89	89
M	mm	1079	1094
Weight	kg	125	170

- 1** Flue gas connection with measuring opening (DN 80)
- 2** Combustion air connection (DN 80)
- 3** Inspection door with measuring opening for combustion air temperature
- 4** Gas connection (TG-6: G ½", TG-9: G ¾")
- 5** Unit control box

Fig. B4: TopVent® TG dimensions and weights

5 Specification texts

5.1 TopVent® TG

Recirculation unit for heating spaces up to 25 m in height with gas-fired heat exchanger; equipped with high-efficiency air distributor; protection rating IP 50.

The unit consists of the following components:

- Fan unit
- Heating section
- Air-Injector or outlet nozzle
- Unit control box
- Optional components

TopVent® TG units comply with all the requirements of the Ecodesign Directive 2009/125/EC relating to environmentally friendly design of energy-related products. They are systems of the 'warm air heater' type, provided for in Commission Regulation (EU) 2016/2281.

Fan unit

Consisting of maintenance-free, direct-drive axial fan with high-efficiency EC motor and balanced rotating wheel with aerodynamically shaped blades and serrated trailing edge (integrated in the heating section).

Heating section

Housing made of magnesium zinc sheet, air-tight, flame retardant, hygienic and easy to maintain because of ageing-resistant, silicone-free sealing materials, configured with: measuring opening for combustion air temperature and large inspection door for easy access to the burner unit and heat exchanger. The heating section contains:

- the burner unit consisting of gas blower and modulating premix burner for low-emission combustion of natural gas
- the burner control for energy-optimised operation, function monitoring and alarm management
- the pull-out heat exchanger consisting of high-quality stainless steel

Air-Injector

Housing made of magnesium zinc sheet, air-tight, flame retardant, hygienic and easy to maintain because of ageing-resistant, silicone-free sealing materials, with:

- Vortex air distributor with concentric outlet nozzle, adjustable vanes and integrated absorber hood
- Actuator for infinitely variable adjustment of the air distribution from vertical to horizontal
 - for draught-free air distribution in the hall under changing operating conditions
 - for the rapid and large-area reduction of temperature stratification in the room through induction of secondary air and strong mixing of the room air with supply air
- Supply air temperature sensor

Outlet nozzle (variant)

Housing made of magnesium zinc sheet, air-tight, flame retardant, hygienic and easy to maintain because of ageing-resistant, silicone-free sealing materials. Concentric outlet nozzle with a supply air sensor.

Unit control box

Control box fitted at the side of the unit for connection of the power supply and housing the control components that facilitate energy-optimised operation, controlled by the control system TopTronic® C. Plastic casing, protection rating IP 56. The following components are installed:

- Isolation switch
- Circuit board with all necessary electrical components and unit controller (connected to the burner control via Modbus)

The circuit board is fitted with push-in terminals facilitating easy installation of the connection cables. All components in the unit control box as well as sensors and actuators in the unit are fully factory-wired.

Power supply and bus connection to be installed on site.

Options for the unit

Suspension set

For ceiling installation of the unit consisting of 4 pairs U-profiles made of magnesium zinc sheet, height-adjustable to 1300 mm

Filter box

Housing made of magnesium zinc sheet with 2 ISO coarse 60% bag filters (G4), with differential pressure switch for filter monitoring, factory-wired to the circuit board in the unit control box

Flat filter box

Housing made of magnesium zinc sheet with 4 pleated ISO coarse 60% cell filters (G4), with differential pressure switch for filter monitoring, factory-wired to the circuit board in the unit control box

Standard paint finish

Exterior painting in Hoval red (RAL 3000), including optional components and suspension set

Paint finish as desired

Exterior painting of the unit in choice of RAL colour, including optional components and suspension set

Recirculation silencer

As an attachment to the unit, made of magnesium zinc sheet, lined with sound insulation matting, insertion attenuation 3 dB

Acoustic cowl

Consisting of an absorber hood of large volume, insertion attenuation 4 dB

Flue gas kit flat roof

Supply air and flue gas system, painted grey RAL 7021, consisting of roof feed-through, flat roof flange, flue gas pipe, T-piece, condensate cap and 90° elbow

Flue gas kit pitched roof

Supply air and flue gas system, painted grey RAL 7021, consisting of roof feed-through, flat roof flange, lead pan with shell, flue gas pipe, T-piece, condensate cap and 90° elbow

Flue gas kit wall

Supply air and flue gas system, painted grey RAL 7021, consisting of wall feed-through, flue gas pipe, T-piece and condensate cap

Individual components of flue gas accessories

- Flue gas pipe (250 / 500 / 1000 mm)
- Elbow (90° / 45°)
- T-piece
- Length adjustment piece
- Condensate cap
- Pipe clamp

5.2 TopTronic® C – System control

Zone-based control system for the energy-optimised operation of decentralised Hoval indoor climate systems. Maximum system size per system bus: 64 control zones with up to 10 supply and extract air handling units or supply air handling units and 10 recirculation air handling units each.

Zone allocation

Configured in advance for the customer at the factory:

	Room designation	Unit type
Zone 1:	_____	_____
Zone 2:	_____	_____
...		

System structure

- Zone control panel made of coated sheet steel (light grey RAL 7035), ... x ... x ... mm, with:
 - System operator terminal
 - Fresh air temperature sensor
 - 1 zone controller and 1 room temperature sensor per zone (expandable to up to 4 room temperature sensors per zone)
 - Safety relay
 - Electrical cabinet internally pre-wired, all components routed to terminals
- Zone bus: as serial bus for communication with all controllers in one control zone, with robust bus protocol via shielded, twisted bus cable (provided by the client)
- Unit controller: installed in the particular indoor climate unit, works autonomously according to the specifications of the zone controller
- Heating/cooling demand per zone with feedback monitoring

Functions, standard

- Zone-based autonomous room control. Temperature and ventilation control separately adjustable for each zone
- Room temperature control via room-supply air cascade by means of energy-optimised double sequence control with priority circuit for energy recovery (supply and extract air handling units)
- Intelligent automatic heating to reach the desired room temperature at the switching time
- 5 adjustable room temperature set values per zone:
 - Cooling protection (lower setpoint in standby)
 - Overheating protection (upper setpoint in standby)
 - Room set value winter
 - Room set value summer
 - Night cooling set value (free cooling) (supply and extract air handling units)
- Destratification mode for even temperature distribution

- Main operating modes of supply and extract air handling units:
 - VE Ventilation, infinitely variably adjustment
 - AQ.... Air quality, automatic control with Hoval combination sensor (option), optional reference variable:
 - CO₂ or VOC
 - Air humidity (optimised dehumidification mode)
 - REC . Recirculation, infinitely variably adjustment
 - DES.. Destratification
 - EA Exhaust air, infinitely variably adjustment
 - SA Supply air, infinitely variably adjustment
 - ST Standby
- Main operating modes of supply air units:
 - REC . Recirculation, infinitely variably adjustment
 - DES.. Destratification
 - SA Supply air, infinitely variably adjustment
 - With Hoval combination sensor (option) also demand-driven control of the fresh air ratio, optional reference variable CO₂ or VOC
 - ST Standby
- Main operating modes of recirculated air units:
 - REC . Recirculation, infinitely variably adjustment
 - DES.. Destratification
 - ST Standby
- Forced heating (construction site heating) can be activated on each device before completion of the overall system (activation by Hoval service technician)
- Control of draught-free air distribution with the Hoval Air-Injector: the discharge direction is adjusted infinitely variably and automatically according to the respective operating condition and the existing temperatures (heating/cooling).

Operation

- TopTronic® C-ST system operator terminal: touch panel for visualisation and control of all Hoval indoor climate units registered on the bus

Options for operation

- Hoval C-SSR operating software, for visualisation on customer's PC
- TopTronic® C-ZT as zone operator terminal: for simple on-site operation of a control zone
- Manual operating selector switches
- Manual operating selector buttons
- Operating of the units via building management system via standardised interfaces:
 - BACnet
 - Modbus IP
 - Modbus RTU

Alarms, protection

- Central alarm management with registration of all alarms (timestamp, priority, status) in an alarm list and alarm memory of the last 50 alarms; forwarding via e-mail can be set in the parameters.
- If there is a failure of communication, bus stations, sensor systems or supply media, each part of the system transitions to a protection mode which safeguards operation.
- A maintenance mode implemented in the control algorithm for testing all physical data points and alarms guarantees high reliability.
- Pre-programmed data points retrievable via logger function for 1 year

Options for the zone control panel

- Alarm lamp
- Socket

Per zone:

- The change-over between heating and cooling can be either automatic or manual
 - Cooling lock switch for automatic changeover
 - Heating/cooling switch for manual changeover
- Additional room temperature sensors (max. 3)
- Combination sensor room air quality, temperature and humidity
- Combination sensor fresh air temperature and humidity
- Transfer of actual values and setpoints from external systems (0...10 V; 4 - 20 mA)
- Load shedding input
- Signal for external extract air fan
- Operating selector switches on terminal
- Operating selector button on terminal
- Control of distributor pump, incl. power supply

Power distribution:

- Circuit breakers and output terminals for Hoval indoor climate units
- Safety relay (4-pin)

5.3 TopTronic® C – System control for TopVent® C-SYS

Control system for the energy-optimised operation of decentralised Hoval indoor climate systems. Maximum system size per system bus: 1 control zone with up to 6 supply air handling units and 10 recirculation air handling units.

System structure

- Zone control panel, designed as compact cabinet for wall installation, made of coated sheet steel (light grey RAL 7035), 380 × 300 × 210 mm, with:
 - Operating panel
 - Zone controller
 - Fresh air temperature sensor
 - 1 Room temperature sensor (expandable to up to 4 room temperature sensors)
 - Safety relay
 - Electrical cabinet internally pre-wired
- Zone bus: as serial bus for communication with all controllers in the control zone, with robust bus protocol via shielded, twisted bus cable (provided by the client)
- Unit controller: installed in the particular indoor climate unit, works autonomously according to the specifications of the zone controller
- Circuit board with external connections for:
 - Power supply
 - Zone bus
 - Room temperature sensors (max. 4)
 - Fresh air temperature sensor
 - Combination sensor room air quality, temperature and humidity
 - Collective alarm
 - Forced off
 - Heating demand
 - Setpoint heating demand
 - Fault heat supply
 - Cooling demand
 - Fault cold supply
 - External enabling heating/cooling (for automatic changeover)
 - External setting heating/cooling (for manual changeover)
 - Changeover valves heating/cooling
 - External setpoint fresh air ratio
 - Operating selector switch on terminal (digital)
 - Operating selector button on terminal

Functions, standard

- Room temperature control via sequential control of the coils
- Intelligent automatic heating to reach the desired room temperature at the switching time
- 4 adjustable room temperature set values per zone:
 - Cooling protection (lower setpoint in standby)
 - Overheating protection (upper setpoint in standby)
 - Room set value winter
 - Room set value summer

- Destratification mode for even temperature distribution
- Main operating modes of supply air units:
 - REC . Recirculation, infinitely variably adjustment
 - DES.. Destratification
 - SA Supply air, infinitely variably adjustment
 - With Hoval combination sensor (option) also demand-driven control of the fresh air ratio, optional reference variable CO₂ or VOC
 - ST Standby
- Main operating modes of recirculated air units:
 - REC . Recirculation, infinitely variably adjustment
 - DES.. Destratification
 - ST Standby
- Forced heating (construction site heating) can be activated on each device before completion of the overall system (activation by Hoval service technician)
- Control of draught-free air distribution with the Hoval Air-Injector: the discharge direction is adjusted infinitely variably and automatically according to the respective operating condition and the existing temperatures (heating/cooling).

Operation

- Operating panel with LCD display, installed in the door of the zone control panel for visualisation and control of all Hoval indoor climate units registered on the bus

Options for operation

- Operating of the units via building management system via standardised interfaces:
 - BACnet
 - Modbus IP
 - Modbus RTU

Alarms, protection

- Central alarm management with registration of all alarms (timestamp, priority, status) in an alarm list and alarm memory of the last 50 alarms; forwarding via e-mail can be set in the parameters.
- If there is a failure of communication, bus stations, sensor systems or supply media, each part of the system transitions to a protection mode which safeguards operation.
- A maintenance mode implemented in the control algorithm for testing all physical data points and alarms guarantees high reliability.
- Pre-programmed data points retrievable via logger function for 1 year

Options for the zone control panel

- Additional room temperature sensors (max. 3)
- Combination sensor room air quality, temperature and humidity
- Signal for external extract air fan

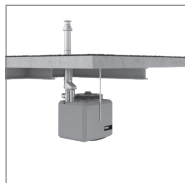

TopVent® GV

Recirculation units for heating spaces up to 6 m in height with gas-fired heat exchanger

1 Use	20
2 Construction and operation	20
3 Technical data	24
4 Dimensions and weights.	26
5 Specification texts	27



1 Use

1.1 Intended use

TopVent® GV units are recirculation units for heating spaces up to 6 m in height with gas-fired heat exchanger. They have the following functions:

- Heating with gas-fired heat exchanger
- Recirculation operation
- Air distribution via air outlet louvre

TopVent® GV units comply with all the requirements of the Ecodesign Directive 2009/125/EC relating to environmentally friendly design of energy-related products. They are systems of the 'warm air heater' type, provided for in Commission Regulation (EU) 2016/2281.

The energy-efficient, demand-oriented operation of TopVent® GV units is ensured either by the TempTronic MTC room temperature controller or the zone-based Hoval TopTronic® C control system, which also enables combination with other Hoval indoor climate units, control of several control zones as well as individual switching of the units.

Intended use also includes compliance with the operating instructions. Any usage over and above this use is considered to be not as intended. The manufacturer can accept no liability for damage resulting from improper use.

1.2 User group

The units are only allowed to be installed, operated and maintained by authorised and instructed personnel who are well acquainted with the units and are informed about possible dangers.

2 Construction and operation

2.1 Construction

The TopVent® GV unit consists of the following components:

- Compact casing made of galvanised sheet steel painted in flame red (RAL 3000)
- Axial fan with capacitor motor, maintenance-free and infinitely variable
- Burner unit consisting of gas blower and modulating premix burner, burner control and heat exchanger for heating the supply air
- Air outlet louvre with vanes for manual adjustment of air distribution
- Integrated terminal box for connection to electricity supply.

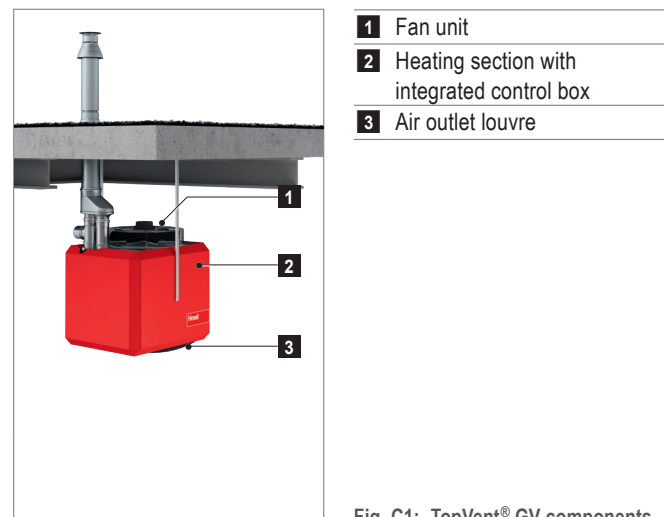
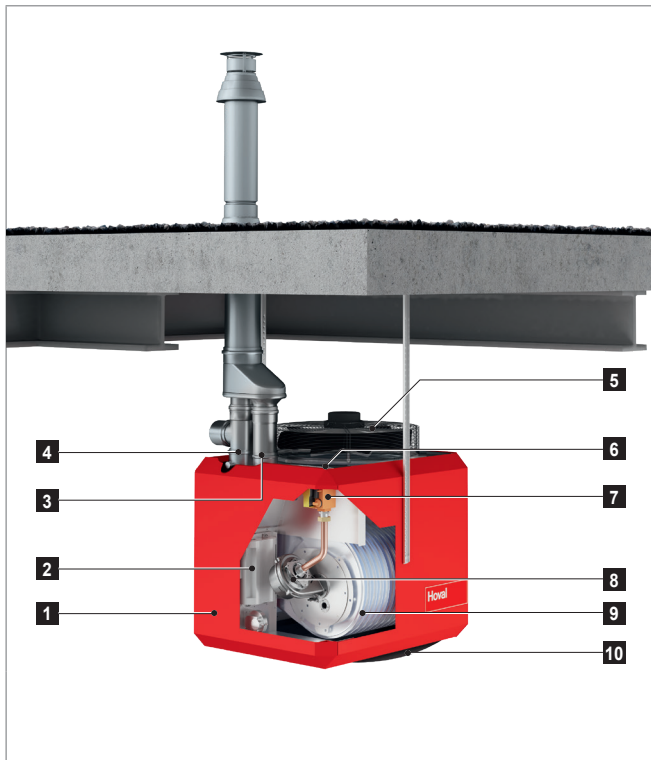

Fig. C1: TopVent® GV components



- 1 Access door
- 2 Burner control
- 3 Combustion air connection
- 4 Flue gas connection
- 5 Fan
- 6 Gas connection
- 7 Gas control valve
- 8 Burner unit consisting of gas blower and premix burner
- 9 Heat exchanger of stainless steel
- 10 Air outlet louvre

Fig. C2: TopVent® GV construction

2.2 Function diagram

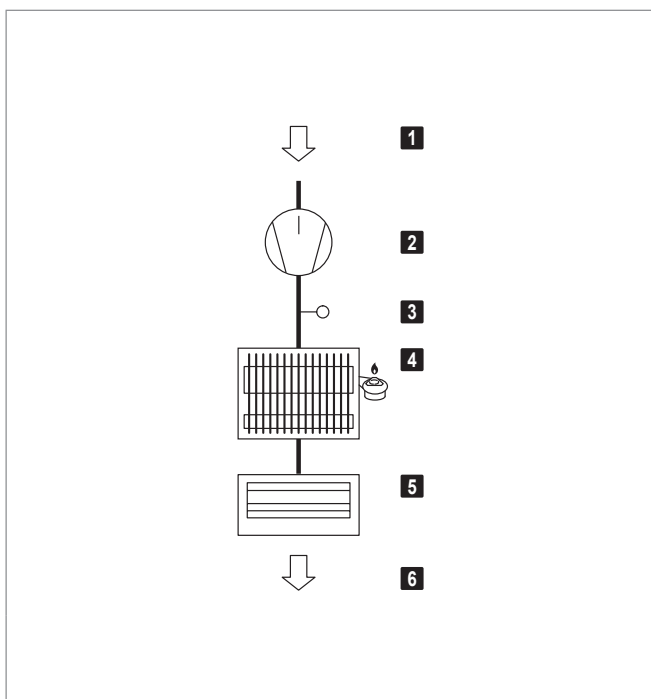

- 1 Extract air
- 2 Fan
- 3 Stratification sensor
- 4 Gas-fired heat exchanger
- 5 Air outlet louvre
- 6 Supply air

Fig. C3: TopVent® GV function diagram

2.3 Operating modes

Operating modes with TopTronic® C

The TopTronic® C control system regulates the following operating modes automatically for each control zone in accordance with the specifications in the calendar:

- Recirculation
- Standby

The following points also apply:

- The operating mode of a control zone can be switched over manually.
- Each TopVent® GV unit can operate individually in a local operating mode: Off, Recirculation.

Code	Operating mode		Description
REC	Recirculation On/off-operation: If heating is required, the unit draws in room air, heats it and blows it back into the room. The room temperature set value day is active.		Fan modulated ¹⁾ Heating modulated ¹⁾ ¹⁾ Depending on heat demand
DES	■ Destratification: To avoid heat build-up under the ceiling, it may be appropriate to switch on the fan when there is no heat demand (either in permanent operation or in on/off operation depending on the temperature stratification, as desired).		Fan on Heating off
ST	Standby The unit is ready for operation. The following operating modes are activated if required:		
CPR	■ Cooling protection: If the room temperature drops below the set value for cooling protection, the unit heats up the room in recirculation operation.		Fan modulated ¹⁾ Heating modulated ¹⁾ ¹⁾ Depending on heat demand
L_OFF	Off (local operating mode) The unit is switched off.		Fan off Heating off

Table C1: Operating modes TopVent® GV with TopTronic® C

Operating modes with TempTronic MTC

The TempTronic MTC controls the following operating modes per control zone:

Operating mode		Description
<p>Recirculation heating</p> <p>The unit draws in room air, warms it and blows it back into the room. 3 setpoints can be set for regulation of the room temperature. The controller operates in one of the following programs, as desired:</p> <ul style="list-style-type: none"> ■ Automatic mode with setpoint changeover according to clock programme ■ Continuous operation with the room temperature setpoint day ■ Continuous operation with the room temperature setpoint night ■ Continuous operation with the room temperature setpoint frost 		<p>Fan modulated ¹⁾</p> <p>Heating modulated ¹⁾</p> <p>¹⁾ Depending on heat demand</p>
<p>Destratification</p> <p>To avoid heat build-up under the ceiling, the fan can be switched on depending on the temperature stratification. The controller compares the air temperatures in the ceiling area and in the occupied area, and switches to destratification mode if the difference becomes too great.</p>		<p>Fan on</p> <p>Heating off</p>
<p>Summer ventilation</p> <p>The fan can be switched manually to 3 speeds.</p>		<p>Fan speed 1 / 2 / 3</p> <p>Heating off</p>

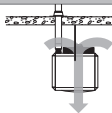
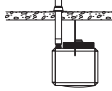
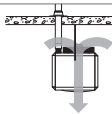
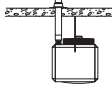
Table C2: Operating modes TopVent® GV with TempTronic MTC

3 Technical data

3.1 Type code

GV - 5 G	
Unit type	TopVent® GV
Unit size	3 or 5
Heating section	F with coil type F (output 30 kW) G with coil type G (output 50 kW)

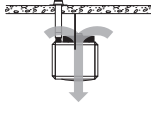
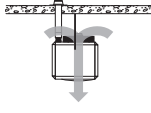
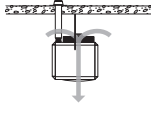
Table C3: TopVent® GV type code

3.2 Application limits

Extract air temperature	max.	°C	50
Supply air temperature	max.	°C	55
The units cannot be used in:			
<ul style="list-style-type: none"> ■ Damp locations ■ Places with a corrosive or aggressive environment ■ Spaces with a large amount of dust ■ Areas where there is danger of explosion 			

Table C4: TopVent® GV application limits

3.3 Electrical connection

Unit type		GV-3	GV-5
Supply voltage	V AC	230	230
Permitted voltage tolerance	%	+10/-15	+10/-15
Frequency	Hz	50	50
Power consumption	W	300	750
Current consumption max.	A	1.4	3.5
Series fuse	A	16	16
Protection rating	–	IP 00B	IP 00B

Table C5: TopVent® GV electrical connection

3.4 Air flow rate, gas consumption

Unit type		GV-3	GV-5	
Nominal air flow rate ¹⁾	m³/h	4200	8500	
Minimum air flow rate	m³/h	2900	6000	
Floor area covered	m²	140	290	
Nominal heat input	min. kW	18.0	33.0	
	max. kW	32.0	55.0	
Nominal heat output	min. kW	17.0	31.5	
	max. kW	28.9	50.7	
Gas consumption				
Natural gas: G20, G27 (H, E, Lw)		m³/h	3.4	5.8
Natural gas: G25, G25.3 (L, LL, K)		m³/h	3.8	6.6

¹⁾ at an air temperature of 20 °C

Table C6: TopVent® GV technical data

3.5 Gas connection

Unit type	GV-3	GV-5	
Gas appliance type ¹⁾	B ₂₃ , C ₁₃ , C ₃₃	B ₂₃ , C ₁₃ , C ₃₃	
Gas connection	G ½" (internal)	G ¾" (internal)	
Combustion air connection	DN 80	DN 80	
Flue gas connection	DN 80	DN 80	
Max. length of flue gas duct ²⁾			
	Ceiling installation	2 m	2 m
	Wall mounting	6 m	8 m

¹⁾ according to method of flue gas evacuation and combustion air supply

²⁾ Equivalent length of formed parts:

– 90° elbow 2 m

– 45° elbow 1 m

– 90° T-piece ... 2 m

Table C7: TopVent® GV gas circuit connections

3.6 Sound level

Unit type		GV-3	GV-5
Sound pressure level (at a distance of 5 m) ¹⁾	dB(A)	59	64
Total sound power level	dB(A)	84	89

¹⁾ with a hemispherical radiation pattern in a low-reflection room

Table C8: TopVent® GV sound level

3.7 Heat output

Air entry temperature	16 °C			20 °C		
Unit type	Q	t _s	H _{max}	Q	t _s	H _{max}
	kW	°C	m	kW	°C	m
GV-3	28.9	38.4	6.0	28.9	42.4	6.0
GV-5	50.7	35.7	8.0	50.7	39.7	8.0

Legend:
 Q = Nominal heat output
 t_s = Maximum supply air temperature
 H_{max} = Maximum mounting height

Table C9: TopVent® GV heat output, supply air temperatures and mounting heights

3.8 Product information according to ErP

Model	TopVent® GV		Unit	
	GV-3	GV-5		
B ₁ warm air heater	yes			
C ₂ warm air heater	no			
C ₄ warm air heater	no			
Type of fuel	gas			
Capacity	Rated heating capacity (P _{rated,h})	28.9	50.7	kW
	Minimum capacity (P _{min})	17.0	31.5	kW
Useful efficiency	At rated heating capacity (η _{nom})	90.4	92.2	%
	At minimal capacity (η _{pl})	94.6	95.6	%
Electric power consumption	At rated heating capacity (e _{l,max})	0.300	0.750	kW
	At minimal capacity (e _{l,min})	0.270	0.600	kW
	In standby mode (e _{l,sb})	0.004	0.004	kW
Other items	Envelope loss factor (F _{env})	–	–	%
	Ignition burner power consumption (P _{ign})	–	–	kW
	Emissions of nitrogen oxides (GCV) (NO _x)	45	49	mg/kWh
	Emission efficiency (η _{s,flow})	95.1	94.9	%
	Seasonal space heating energy efficiency (η _{s,h})	78.4	78.8	%
Contact details	Hoval Aktiengesellschaft, Austrasse 70, 9490 Vaduz, Liechtenstein www.hoval.com			

Table C10: Product information according to Commission Regulation (EU) 2016/2281, Table 9

4 Dimensions and weights

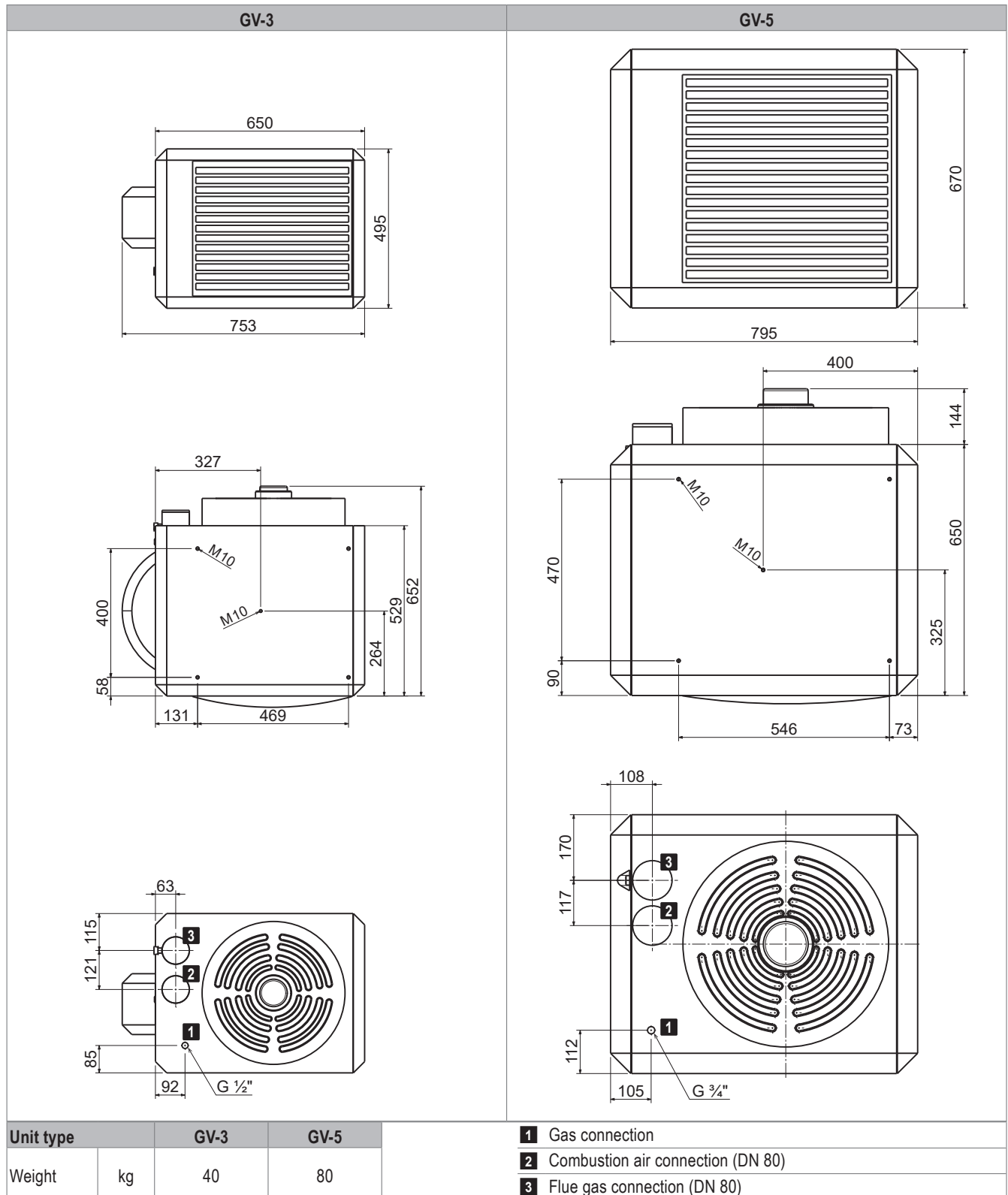

Fig. C4: TopVent® GV dimensions and weights

5 Specification texts

5.1 TopVent® GV

Recirculation unit for heating spaces up to 6 m in height with gas-fired heat exchanger.

The unit consists of the following components:

- Galvanised sheet steel housing, painted in flame red (RAL 3000), with inspection door and 2 x M10 blind rivet nuts for installation of the optional suspension set for ceiling or wall mounting.
- Burner unit consisting of gas blower and modulating premix burner for low-emission combustion of natural gas
- Burner control for energy-optimised operation, function monitoring and alarm management
- Pull-out heat exchanger made of high-quality stainless steel
- Fan unit consisting of a high-efficiency, infinitely variable axial-flow fan with a capacitor motor, maintenance-free and low-noise.
- Terminal box integrated in the housing for connection to electricity supply.
- Air outlet louvre with vanes for manual adjustment of air distribution

TopVent® GV units comply with all the requirements of the Ecodesign Directive 2009/125/EC relating to environmentally friendly design of energy-related products. They are systems of the 'warm air heater' type, provided for in Commission Regulation (EU) 2016/2281.

Options for the unit

Suspension set ceiling

of galvanised sheet steel, height-adjustable up to 1650 mm

Suspension set wall

of galvanised sheet steel, adjustable to the wall separations of 400...640 mm (GV-3) or 420...560 mm (GV-5)

Flue gas kit flat roof

Supply air and flue gas system, painted grey RAL 7021, consisting of roof feed-through, flat roof flange, flue gas pipe, T-piece, condensate cap and 90° elbow

Flue gas kit pitched roof

Supply air and flue gas system, painted grey RAL 7021, consisting of roof feed-through, flat roof flange, lead pan with shell, flue gas pipe, T-piece, condensate cap and 90° elbow

Flue gas kit wall

Supply air and flue gas system, painted grey RAL 7021, consisting of wall feed-through, flue gas pipe, T-piece and condensate cap

Individual components of flue gas accessories

- Flue gas pipe (250 / 500 / 1000 mm)
- Elbow (90° / 45°)
- T-piece
- Length adjustment piece
- Condensate cap
- Pipe clamp

5.2 TopTronic® C – System control

Zone-based control system for the energy-optimised operation of decentralised Hoval indoor climate systems. Maximum system size per system bus: 64 control zones with up to 10 supply and extract air handling units or supply air handling units and 10 recirculation air handling units each.

Zone allocation

Configured in advance for the customer at the factory:

	Room designation	Unit type
Zone 1:	_____	_____
Zone 2:	_____	_____
...		

System structure

- Zone control panel made of coated sheet steel (light grey RAL 7035), ... x ... x ... mm, with:
 - System operator terminal
 - Fresh air temperature sensor
 - 1 zone controller and 1 room temperature sensor per zone (expandable to up to 4 room temperature sensors per zone)
 - Safety relay
 - Electrical cabinet internally pre-wired, all components routed to terminals
- Zone bus: as serial bus for communication with all controllers in one control zone, with robust bus protocol via shielded, twisted bus cable (provided by the client)
- Unit controller: installed in the particular indoor climate unit, works autonomously according to the specifications of the zone controller
- Heating/cooling demand per zone with feedback monitoring

Functions, standard

- Zone-based autonomous room control. Temperature and ventilation control separately adjustable for each zone
- Room temperature control via room-supply air cascade by means of energy-optimised double sequence control with priority circuit for energy recovery (supply and extract air handling units)
- Intelligent automatic heating to reach the desired room temperature at the switching time
- 5 adjustable room temperature set values per zone:
 - Cooling protection (lower setpoint in standby)
 - Overheating protection (upper setpoint in standby)
 - Room set value winter
 - Room set value summer
 - Night cooling set value (free cooling) (supply and extract air handling units)
- Destratification mode for even temperature distribution

- Main operating modes of supply and extract air handling units:

VE Ventilation, infinitely variably adjustment
 AQ.... Air quality, automatic control with Hoval combination sensor (option), optional reference variable:

- CO₂ or VOC
- Air humidity (optimised dehumidification mode)

 REC . Recirculation, infinitely variably adjustment
 DES.. Destratification
 EA Exhaust air, infinitely variably adjustment
 SA Supply air, infinitely variably adjustment
 ST Standby

- Main operating modes of supply air units:

REC . Recirculation, infinitely variably adjustment
 DES.. Destratification
 SA Supply air, infinitely variably adjustment
 With Hoval combination sensor (option) also demand-driven control of the fresh air ratio, optional reference variable CO₂ or VOC
 ST Standby

- Main operating modes of recirculated air units:

REC . Recirculation, infinitely variably adjustment
 DES.. Destratification
 ST Standby

- Forced heating (construction site heating) can be activated on each device before completion of the overall system (activation by Hoval service technician)
- Control of draught-free air distribution with the Hoval Air-Injector: the discharge direction is adjusted infinitely variably and automatically according to the respective operating condition and the existing temperatures (heating/cooling).

Operation

- TopTronic® C-ST system operator terminal: touch panel for visualisation and control of all Hoval indoor climate units registered on the bus

Options for operation

- Hoval C-SSR operating software, for visualisation on customer's PC
- TopTronic® C-ZT as zone operator terminal: for simple on-site operation of a control zone
- Manual operating selector switches
- Manual operating selector buttons
- Operating of the units via building management system via standardised interfaces:
 - BACnet
 - Modbus IP
 - Modbus RTU

Alarms, protection

- Central alarm management with registration of all alarms (timestamp, priority, status) in an alarm list and alarm memory of the last 50 alarms; forwarding via e-mail can be set in the parameters.
- If there is a failure of communication, bus stations, sensor systems or supply media, each part of the system transitions to a protection mode which safeguards operation.
- A maintenance mode implemented in the control algorithm for testing all physical data points and alarms guarantees high reliability.
- Pre-programmed data points retrievable via logger function for 1 year

Options for the zone control panel

- Alarm lamp
- Socket

Per zone:

- The change-over between heating and cooling can be either automatic or manual
 - Cooling lock switch for automatic changeover
 - Heating/cooling switch for manual changeover
- Additional room temperature sensors (max. 3)
- Combination sensor room air quality, temperature and humidity
- Combination sensor fresh air temperature and humidity
- Transfer of actual values and setpoints from external systems (0...10 V; 4 - 20 mA)
- Load shedding input
- Signal for external extract air fan
- Operating selector switches on terminal
- Operating selector button on terminal
- Control of distributor pump, incl. power supply

Power distribution:

- Circuit breakers and output terminals for Hoval indoor climate units
- Safety relay (4-pin)

5.3 TopTronic® C – System control for TopVent® C-SYS

Control system for the energy-optimised operation of decentralised Hoval indoor climate systems. Maximum system size per system bus: 1 control zone with up to 6 supply air handling units and 10 recirculation air handling units.

System structure

- Zone control panel, designed as compact cabinet for wall installation, made of coated sheet steel (light grey RAL 7035), 380 × 300 × 210 mm, with:
 - Operating panel
 - Zone controller
 - Fresh air temperature sensor
 - 1 Room temperature sensor (expandable to up to 4 room temperature sensors)
 - Safety relay
 - Electrical cabinet internally pre-wired
- Zone bus: as serial bus for communication with all controllers in the control zone, with robust bus protocol via shielded, twisted bus cable (provided by the client)
- Unit controller: installed in the particular indoor climate unit, works autonomously according to the specifications of the zone controller
- Circuit board with external connections for:
 - Power supply
 - Zone bus
 - Room temperature sensors (max. 4)
 - Fresh air temperature sensor
 - Combination sensor room air quality, temperature and humidity
 - Collective alarm
 - Forced off
 - Heating demand
 - Setpoint heating demand
 - Fault heat supply
 - Cooling demand
 - Fault cold supply
 - External enabling heating/cooling (for automatic changeover)
 - External setting heating/cooling (for manual changeover)
 - Changeover valves heating/cooling
 - External setpoint fresh air ratio
 - Operating selector switch on terminal (digital)
 - Operating selector button on terminal

Functions, standard

- Room temperature control via sequential control of the coils
- Intelligent automatic heating to reach the desired room temperature at the switching time
- 4 adjustable room temperature set values per zone:
 - Cooling protection (lower setpoint in standby)
 - Overheating protection (upper setpoint in standby)
 - Room set value winter
 - Room set value summer

- Destratification mode for even temperature distribution
- Main operating modes of supply air units:
 - REC . Recirculation, infinitely variably adjustment
 - DES.. Destratification
 - SA Supply air, infinitely variably adjustment
 - With Hoval combination sensor (option) also demand-driven control of the fresh air ratio, optional reference variable CO₂ or VOC
 - ST Standby
- Main operating modes of recirculated air units:
 - REC . Recirculation, infinitely variably adjustment
 - DES.. Destratification
 - ST Standby
- Forced heating (construction site heating) can be activated on each device before completion of the overall system (activation by Hoval service technician)
- Control of draught-free air distribution with the Hoval Air-Injector: the discharge direction is adjusted infinitely variably and automatically according to the respective operating condition and the existing temperatures (heating/cooling).

Operation

- Operating panel with LCD display, installed in the door of the zone control panel for visualisation and control of all Hoval indoor climate units registered on the bus

Options for operation

- Operating of the units via building management system via standardised interfaces:
 - BACnet
 - Modbus IP
 - Modbus RTU

Alarms, protection

- Central alarm management with registration of all alarms (timestamp, priority, status) in an alarm list and alarm memory of the last 50 alarms; forwarding via e-mail can be set in the parameters.
- If there is a failure of communication, bus stations, sensor systems or supply media, each part of the system transitions to a protection mode which safeguards operation.
- A maintenance mode implemented in the control algorithm for testing all physical data points and alarms guarantees high reliability.
- Pre-programmed data points retrievable via logger function for 1 year

Options for the zone control panel

- Additional room temperature sensors (max. 3)
- Combination sensor room air quality, temperature and humidity
- Signal for external extract air fan

5.4 TempTronic MTC

Programmable room temperature controller with menu operation for up to 8 TopVent® GV units, protection rating IP 30, with the following functions:

- Regulation of the room temperature with setting option for 3 temperature setpoints
- Clock programme with 10 programmable time blocks
- Summer ventilation (in 3 speeds)
- Destratification mode
- Recording the room temperature with the integrated temperature sensor
- Connection option for external room temperature sensor (instead of the integrated sensor or for averaging)
- Alarm display and reset
- External switching (off/clock program)
- Keyboard locking
- Password protection

Options

- Optional module for connection to the building management system via analogue and digital signals
- External room temperature sensor



TopVent® MG

Recirculation units with efficient air distribution
for ventilation and heating of spaces up to 25 m in height
with gas-fired heat exchanger

1 Use 32

2 Construction and operation 32

3 Technical data 36

4 Dimensions and weights. 38

5 Specification texts 39

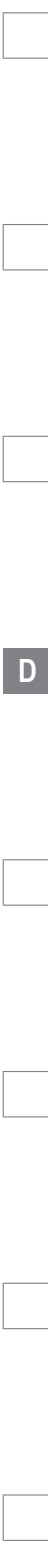

D

1 Use

1.1 Intended use

TopVent® MG units are supply air units for ventilation and heating of spaces up to 25 m in height with gas-fired heat exchanger. They have the following functions:

- Heating with gas-fired heat exchanger
- Fresh air supply
- Mixed air operation
- Recirculation operation
- Air distribution and destratification with adjustable Air-Injector
- Air filtration

TopVent® MG units comply with all the requirements of the Ecodesign Directive 2009/125/EC relating to environmentally friendly design of energy-related products. They are systems of the 'warm air heater' type, provided for in Commission Regulation (EU) 2016/2281.

The Hoval TopTronic® C integrated control system ensures energy-efficient, demand-based operation of Hoval indoor climate systems.

Intended use also includes compliance with the operating instructions. Any usage over and above this use is considered to be not as intended. The manufacturer can accept no liability for damage resulting from improper use.

1.2 User group

The units are only allowed to be installed, operated and maintained by authorised and instructed personnel who are well acquainted with the units and are informed about possible dangers.

2 Construction and operation

2.1 Construction

The TopVent® MG unit consists of the following components:

- Fan unit:
Axial fan with energy-saving EC motor, maintenance-free and infinitely variable
- Heating section:
The heating section contains the burner unit consisting of gas blower and modulating premix burner, the burner control and the heat exchanger for heating the supply air.
- Air-Injector:
The Air-Injector is a patented, infinitely variable vortex air distributor for the draught-free introduction of air into the hall under changing operating conditions.
- Filter box:
The filter box contains 2 ISO Coarse 60% bag filters (G4), easily accessible behind the sliding door.
- Mixed air box:
The mixed air box contains fresh air damper and recirculation damper linked to move in opposite directions and actuator with spring return.

As part of the TopTronic® C control system, the unit control box is an integral component.

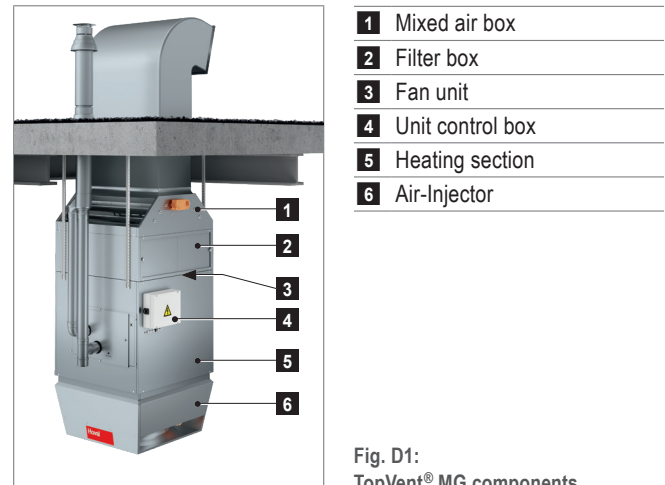
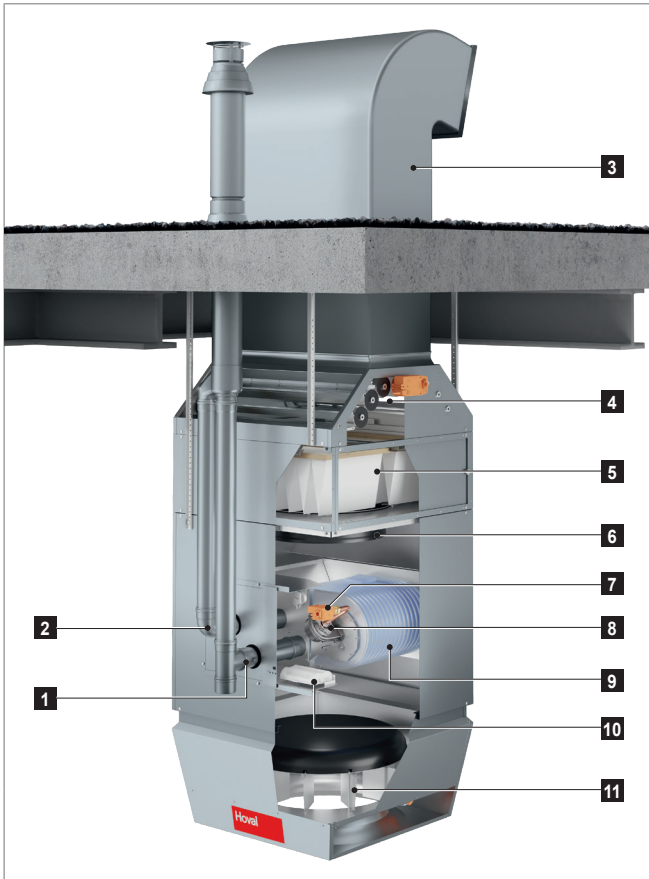

Fig. D1:
TopVent® MG components



- 1 Flue gas connection
- 2 Combustion air connection
- 3 Fresh air duct (not included in the Hoval scope of supply)
- 4 Mixed air box
- 5 Filter box
- 6 Fan
- 7 Gas control valve and gas connection
- 8 Burner unit consisting of gas blower and premix burner
- 9 Heat exchanger of stainless steel
- 10 Burner control
- 11 Air-Injector

Fig. D2: TopVent® MG construction

2.2 Function diagram

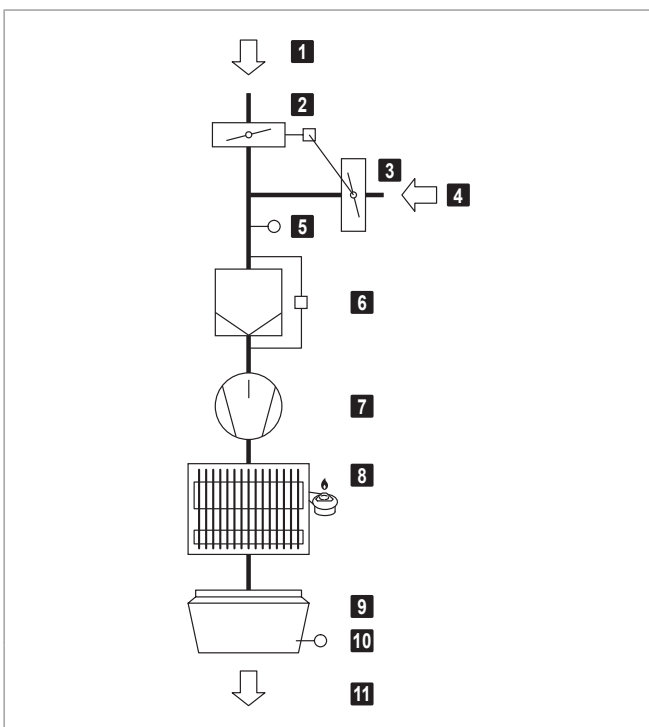

- 1 Fresh air
- 2 Fresh air damper with actuator
- 3 Recirculation damper (opposed to the fresh air damper)
- 4 Extract air
- 5 Mixed air temperature sensor
- 6 Air filter with differential pressure switch
- 7 Fan
- 8 Gas-fired heat exchanger
- 9 Air-Injector with actuator
- 10 Supply air temperature sensor
- 11 Supply air

Fig. D3: TopVent® MG function diagram



2.3 Operating modes

TopVent® MG operates in the following modes:

- Supply air speed 2
- Supply air speed 1
- Recirculation
- Recirculation speed 1
- Standby

The TopTronic® C control system regulates these operating modes automatically for each control zone in accordance with the specifications in the calendar. The following points also apply:

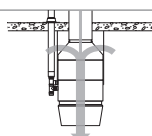
- The operating mode of a control zone can be switched over manually.
- Each TopVent® MG unit can operate individually in a local operating mode: Off, Supply air speed 2, Supply air speed 1, Recirculation, Recirculation speed 1.

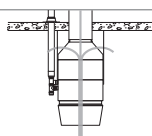
Code	Operating mode		Description
SA2	Supply air speed 2 The fan runs at speed 2 (high air flow rate). The room temperature set value day is active. The unit blows fresh air into the room. The control of the fresh air ratio can be selected:		
	<u>Fixed fresh air ratio:</u> The unit operates continuously with the set fresh air ratio. The system controls the heating according to the heating demand.		Fan speed 2 Fresh air damper..... 10 % open ¹⁾ Heating 0-100 % ²⁾ 1) Percentage is adjustable 2) Depending on heat demand
	<u>Variable fresh air ratio:</u> <ul style="list-style-type: none"> ■ The system regulates the fresh air ratio depending on the temperature. The set fresh air ratio serves as a minimum value. If the temperature conditions permit, more fresh air is brought into the room and used for free heating or free cooling. Only when this potential is fully utilised is the heating switched on via the coil if required. ■ If a combination sensor for room air is installed (option), the system additionally controls the fresh air ratio depending on the air quality. <ul style="list-style-type: none"> – If there is no heat demand, the fresh air damper is opened 100% if the indoor air quality is too poor. – When the setpoint value for the CO₂ or VOC content of the room air is reached, the fresh air damper closes again to the set minimum value. 		Fan speed 2 Fresh air damper..... MIN-100 % open ¹⁾ Heating 0-100 % ²⁾ 1) A minimum value can be set 2) Depending on heat demand
 Notice In order to save heating energy, the unit only operates with the set minimum fresh air rate when heat is required.			
SA1	Supply air speed 1 The same as SA2, but the unit operates at speed 1 (low air flow rate)		Fan speed 1 Fresh air damper..... MIN-100 % open ¹⁾ Heating 0-100 % ²⁾ 1) Fixed or variable (see above) 2) Depending on heat demand

Code	Operating mode		Description
REC	Recirculation On/off-operation: If heating is required, the unit draws in room air, heats it and blows it back into the room. The room temperature set value day is active.		Fan speed 1/2 ¹⁾ Fresh air damper..... closed Heating on ¹⁾ 1) Depending on heat demand
DES	<ul style="list-style-type: none"> ■ Destratification: To avoid heat build-up under the ceiling, it may be appropriate to switch on the fan when there is no heat demand (either in permanent operation or in on/off operation depending on the temperature stratification, as desired). 		Fan speed 2 Fresh air damper..... closed Heating off
REC1	Recirculation speed 1 The same as REC, but the unit operates only at speed 1 (low air flow rate)		Fan speed 1 ¹⁾ Fresh air damper..... closed Heating on ¹⁾ 1) Depending on heat demand
DES	<ul style="list-style-type: none"> ■ Destratification: The same as for REC, but the unit operates only at speed 1 		Fan speed 1 Fresh air damper..... closed Heating off
ST	Standby The unit is ready for operation. The following operating modes are activated if required:		
CPR	<ul style="list-style-type: none"> ■ Cooling protection: If the room temperature drops below the set value for cooling protection, the unit heats up the room in recirculation operation. 		Fan speed 2 Fresh air damper..... closed Heating on
NCS	<ul style="list-style-type: none"> ■ Night cooling: If the room temperature exceeds the set value for night cooling and the current fresh air temperature permits it, the unit blows cool fresh air into the room and extracts warmer room air. 		Fan speed 2 Fresh air damper..... open Heating off
L_OFF	Off (local operating mode) The unit is switched off.		Fan off Fresh air damper..... closed Heating off

Table D1: TopVent® MG operating modes

3 Technical data

3.1 Type code

MG - 6 F - ...	
Unit type	TopVent® MG
Unit size	6 or 9
Heating section	F with coil type F (output 30 kW) H with coil type H (output 60 kW)
Options	

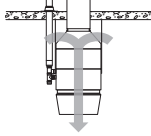
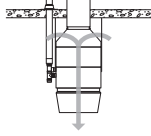
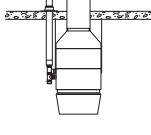
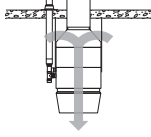
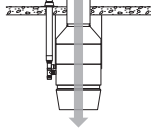
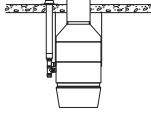
Table D2: TopVent® MG type code

3.2 Application limits

Extract air temperature	max.	°C	50
Fresh air temperature	min.	°C	-15
Supply air temperature	max.	°C	55
Protection rating			IP 50
The units cannot be used in:			
<ul style="list-style-type: none"> ■ Damp locations ■ Places with a corrosive or aggressive environment ■ Spaces with a large amount of dust ■ Areas where there is danger of explosion 			

Table D3: TopVent® MG application limits

3.3 Electrical connection

Unit type		MG-6	MG-9
Supply voltage	V AC	3 x 400	3 x 400
Permitted voltage tolerance	%	± 5	± 5
Frequency	Hz	50	50
Power consumption	W	1360	1960
Current consumption max.	A	2.3	3.4
Series fuse	A	13	13
Protection rating of unit control box	-	IP 56	IP 56

Table D4: TopVent® MG electrical connection

3.4 Air flow rate, gas consumption

Unit type		MG-6	MG-9
Nominal air flow rate ¹⁾	m³/h	7000	11000
Minimum air flow rate	m³/h	5000	9000
Floor area covered	m²	644	1232
Nominal heat input	max. kW	32.0	66.0
Nominal heat output	max. kW	28.9	61.2
Gas consumption			
Natural gas: G20, G27 (H, E, Lw)	m³/h	3.4	7.0
Natural gas: G25, G25.3 (L, LL, K)	m³/h	3.8	7.9

¹⁾ at an air temperature of 20 °C

Table D5: TopVent® MG technical data

3.5 Gas connection

Unit type	MG-6	MG-9
Gas appliance type ¹⁾	B ₂₃ , C ₁₃ , C ₃₃	B ₂₃ , C ₁₃ , C ₃₃
Gas connection	G ½" (internal)	G ¾" (internal)
Combustion air connection	DN 80	DN 80
Flue gas connection	DN 80	DN 80
Max. length of flue gas duct ²⁾	6 m	8 m

¹⁾ according to method of flue gas evacuation and combustion air supply
²⁾ Equivalent length of formed parts:
 - 90° elbow 2 m
 - 45° elbow 1 m
 - 90° T-piece... 2 m

Table D6: TopVent® MG gas circuit connections

3.6 Sound levels

Unit type		MG-6	MG-9
Sound pressure level (at a distance of 5 m) ¹⁾	dB(A)	58	61
Total sound power level	dB(A)	80	83
Octave sound power level	63 Hz	dB	57
	125 Hz	dB	62
	250 Hz	dB	67
	500 Hz	dB	72
	1000 Hz	dB	77
	2000 Hz	dB	74
	4000 Hz	dB	68
	8000 Hz	dB	60

¹⁾ with a hemispherical radiation pattern in a low-reflection room

Table D7: TopVent® MG sound power levels

3.7 Heat output

Fresh air temperature	-5 °C			-15 °C		
	Q	t _s	H _{max}	Q	t _s	H _{max}
Unit type	kW	°C	m	kW	°C	m
MG-6	28.9	29.8	19.1	28.9	28.8	19.9
MG-9	61.2	34.0	18.3	61.2	33.0	18.9
Legend:	Q = Nominal heat output t _s = Maximum supply air temperature H _{max} = Maximum mounting height					
Reference:	■ Room air 18 °C, extract air 20 °C / 20 % rel. humidity ■ Fresh air ratio 10 %					

Table D8: TopVent® MG heat output, supply air temperatures and mounting heights

3.8 Product information according to ErP

Model	TopVent® MG		Unit	
	MG-6	MG-9		
B ₁ warm air heater	yes			
C ₂ warm air heater	no			
C ₄ warm air heater	no			
Type of fuel	gas			
Capacity	Rated heating capacity (P _{rated,h})	28.9	61.2	kW
	Minimum capacity (P _{min})	17.0	37.9	kW
Useful efficiency	At rated heating capacity (η _{nom})	90.4	92.7	%
	At minimal capacity (η _{pl})	94.6	95.6	%
Electric power consumption	At rated heating capacity (e _{l,max})	1.219	1.559	kW
	At minimal capacity (e _{l,min})	0.617	0.975	kW
	In standby mode (e _{l,sb})	0.034	0.034	kW
Other items	Envelope loss factor (F _{env})	–	–	%
	Ignition burner power consumption (P _{ign})	–	–	kW
	Emissions of nitrogen oxides (GCV) (NO _x)	45	45	mg/kWh
	Emission efficiency (η _{s,flow})	95.1	94.0	%
	Seasonal space heating energy efficiency (η _{s,h})	79.3	79.4	%
Contact details	Hoval Aktiengesellschaft, Austrasse 70, 9490 Vaduz, Liechtenstein www.hoval.com			

Table D9: Product information according to Commission Regulation (EU) 2016/2281, Table 9

4 Dimensions and weights

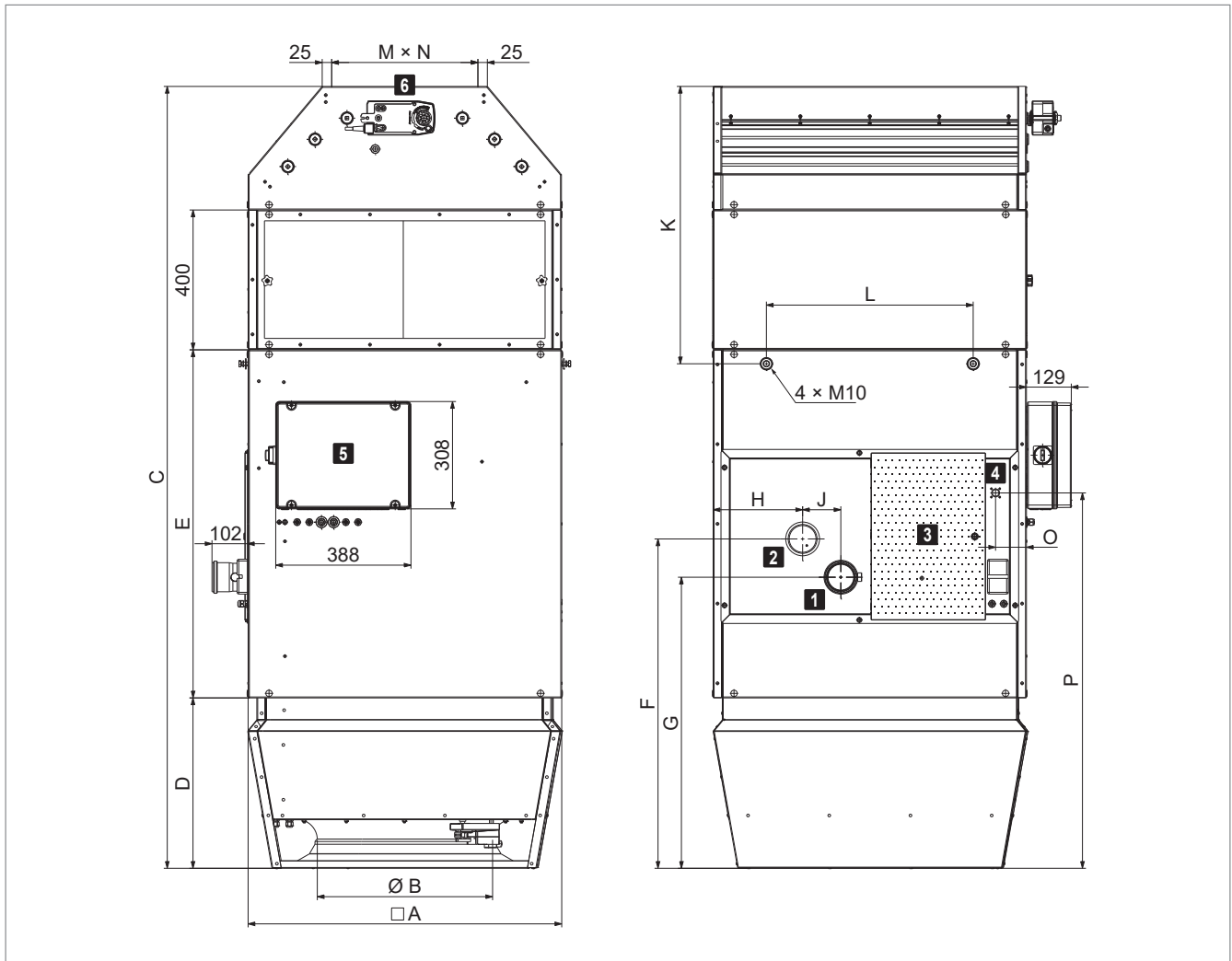

Unit type		MG-6	MG-9
A	mm	900	1100
B	mm	500	630
C	mm	2246	2333
D	mm	490	570
E	mm	1000	1000
F	mm	946	1019
G	mm	836	909
H	mm	257	461
J	mm	110	110
K	mm	797	803
L	mm	594	846
M x N	mm	420 x 850	500 x 1050
O	mm	89	89
P	mm	1079	1094
Weight	kg	175	230

- 1** Flue gas connection with measuring opening (DN 80)
- 2** Combustion air connection (DN 80)
- 3** Inspection door with measuring opening for combustion air temperature
- 4** Gas connection (MG-6: G 1/2", MG-9: G 3/4")
- 5** Unit control box
- 6** Fresh air duct connection

Fig. D4: TopVent® MG dimensions and weights

5 Specification texts

5.1 TopVent® MG

Supply air unit for ventilation and heating of spaces up to 25 m in height with gas-fired heat exchanger; equipped with high-efficiency air distributor; protection rating IP 50.

The unit consists of the following components:

- Fan unit
- Heating section
- Air-Injector
- Filter box
- Mixed air box
- Unit control box
- Optional components

TopVent® MG units comply with all the requirements of the Ecodesign Directive 2009/125/EC relating to environmentally friendly design of energy-related products. They are systems of the 'warm air heater' type, provided for in Commission Regulation (EU) 2016/2281.

Fan unit

Consisting of maintenance-free, direct-drive axial fan with high-efficiency EC motor and balanced rotating wheel with aerodynamically shaped blades and serrated trailing edge (integrated in the heating section).

Heating section

Housing made of magnesium zinc sheet, air-tight, flame retardant, hygienic and easy to maintain because of ageing-resistant, silicone-free sealing materials, configured with: measuring opening for combustion air temperature and large inspection door for easy access to the burner unit and heat exchanger. The heating section contains:

- the burner unit consisting of gas blower and modulating premix burner for low-emission combustion of natural gas
- the burner control for energy-optimised operation, function monitoring and alarm management
- the pull-out heat exchanger consisting of high-quality stainless steel

Air-Injector

Housing made of magnesium zinc sheet, air-tight, flame retardant, hygienic and easy to maintain because of ageing-resistant, silicone-free sealing materials, with:

- Vortex air distributor with concentric outlet nozzle, adjustable vanes and integrated absorber hood
- Actuator for infinitely variable adjustment of the air distribution from vertical to horizontal
 - for draught-free air distribution in the hall under changing operating conditions
 - for the rapid and large-area reduction of temperature stratification in the room through induction of secondary air and strong mixing of the room air with supply air
- Supply air temperature sensor

Filter box

Housing made of magnesium zinc sheet, internally insulated with EPDM, with 2 ISO coarse 60% bag filters (G4), with differential pressure switch for filter monitoring, factory-wired to the circuit board in the unit control box.

Mixed air box

Housing made of magnesium zinc sheet, internally insulated with EPDM, with fresh air damper and recirculation damper linked to move in opposite directions; includes actuator with spring return, factory-wired to the circuit board in the unit control box.

Unit control box

Control box fitted at the side of the unit for connection of the power supply and housing the control components that facilitate energy-optimised operation, controlled by the control system TopTronic® C. Plastic casing, protection rating IP 56. The following components are installed:

- Isolation switch
- Circuit board with all necessary electrical components and unit controller (connected to the burner control via Modbus)

The circuit board is fitted with push-in terminals facilitating easy installation of the connection cables. All components in the unit control box as well as sensors and actuators in the unit are fully factory-wired.

Power supply and bus connection to be installed on site.

Options for the unit

Suspension set

For ceiling installation of the unit consisting of 4 pairs U-profiles made of magnesium zinc sheet, height-adjustable to 1300 mm

Standard paint finish

Exterior painting in Hoval red (RAL 3000), including optional components and suspension set

Paint finish as desired

Exterior painting of the unit in choice of RAL colour, including optional components and suspension set

Acoustic cowl

Consisting of an absorber hood of large volume, insertion attenuation 4 dB

Flue gas kit flat roof

Supply air and flue gas system, painted grey RAL 7021, consisting of roof feed-through, flat roof flange, flue gas pipe, T-piece, condensate cap and 90° elbow

Flue gas kit pitched roof

Supply air and flue gas system, painted grey RAL 7021, consisting of roof feed-through, flat roof flange, lead pan with shell, flue gas pipe, T-piece, condensate cap and 90° elbow

Flue gas kit wall

Supply air and flue gas system, painted grey RAL 7021, consisting of wall feed-through, flue gas pipe, T-piece and condensate cap

Individual components of flue gas accessories

- Flue gas pipe (250 / 500 / 1000 mm)
- Elbow (90° / 45°)
- T-piece
- Length adjustment piece
- Condensate cap
- Pipe clamp

5.2 TopTronic® C – System control

Zone-based control system for the energy-optimised operation of decentralised Hoval indoor climate systems. Maximum system size per system bus: 64 control zones with up to 10 supply and extract air handling units or supply air handling units and 10 recirculation air handling units each.

Zone allocation

Configured in advance for the customer at the factory:

	Room designation	Unit type
Zone 1:	_____	_____
Zone 2:	_____	_____
...		

System structure

- Zone control panel made of coated sheet steel (light grey RAL 7035), ... x ... x ... mm, with:
 - System operator terminal
 - Fresh air temperature sensor
 - 1 zone controller and 1 room temperature sensor per zone (expandable to up to 4 room temperature sensors per zone)
 - Safety relay
 - Electrical cabinet internally pre-wired, all components routed to terminals
- Zone bus: as serial bus for communication with all controllers in one control zone, with robust bus protocol via shielded, twisted bus cable (provided by the client)
- Unit controller: installed in the particular indoor climate unit, works autonomously according to the specifications of the zone controller
- Heating/cooling demand per zone with feedback monitoring

Functions, standard

- Zone-based autonomous room control. Temperature and ventilation control separately adjustable for each zone
- Room temperature control via room-supply air cascade by means of energy-optimised double sequence control with priority circuit for energy recovery (supply and extract air handling units)
- Intelligent automatic heating to reach the desired room temperature at the switching time
- 5 adjustable room temperature set values per zone:
 - Cooling protection (lower setpoint in standby)
 - Overheating protection (upper setpoint in standby)
 - Room set value winter
 - Room set value summer
 - Night cooling set value (free cooling) (supply and extract air handling units)
- Destratification mode for even temperature distribution

- Main operating modes of supply and extract air handling units:

VE Ventilation, infinitely variably adjustment

AQ.... Air quality, automatic control with Hoval combination sensor (option), optional reference variable:

- CO₂ or VOC
- Air humidity (optimised dehumidification mode)

REC . Recirculation, infinitely variably adjustment

DES.. Destratification

EA Exhaust air, infinitely variably adjustment

SA Supply air, infinitely variably adjustment

ST Standby

- Main operating modes of supply air units:

REC . Recirculation, infinitely variably adjustment

DES.. Destratification

SA Supply air, infinitely variably adjustment

With Hoval combination sensor (option) also demand-driven control of the fresh air ratio, optional reference variable CO₂ or VOC

ST Standby

- Main operating modes of recirculated air units:

REC . Recirculation, infinitely variably adjustment

DES.. Destratification

ST Standby

- Forced heating (construction site heating) can be activated on each device before completion of the overall system (activation by Hoval service technician)
- Control of draught-free air distribution with the Hoval Air-Injector: the discharge direction is adjusted infinitely variably and automatically according to the respective operating condition and the existing temperatures (heating/cooling).

Operation

- TopTronic® C-ST system operator terminal: touch panel for visualisation and control of all Hoval indoor climate units registered on the bus

Options for operation

- Hoval C-SSR operating software, for visualisation on customer's PC
- TopTronic® C-ZT as zone operator terminal: for simple on-site operation of a control zone
- Manual operating selector switches
- Manual operating selector buttons
- Operating of the units via building management system via standardised interfaces:
 - BACnet
 - Modbus IP
 - Modbus RTU

Alarms, protection

- Central alarm management with registration of all alarms (timestamp, priority, status) in an alarm list and alarm memory of the last 50 alarms; forwarding via e-mail can be set in the parameters.
- If there is a failure of communication, bus stations, sensor systems or supply media, each part of the system transitions to a protection mode which safeguards operation.
- A maintenance mode implemented in the control algorithm for testing all physical data points and alarms guarantees high reliability.
- Pre-programmed data points retrievable via logger function for 1 year

Options for the zone control panel

- Alarm lamp
- Socket

Per zone:

- The change-over between heating and cooling can be either automatic or manual
 - Cooling lock switch for automatic changeover
 - Heating/cooling switch for manual changeover
- Additional room temperature sensors (max. 3)
- Combination sensor room air quality, temperature and humidity
- Combination sensor fresh air temperature and humidity
- Transfer of actual values and setpoints from external systems (0...10 V; 4 - 20 mA)
- Load shedding input
- Signal for external extract air fan
- Operating selector switches on terminal
- Operating selector button on terminal
- Control of distributor pump, incl. power supply

Power distribution:

- Circuit breakers and output terminals for Hoval indoor climate units
- Safety relay (4-pin)

5.3 TopTronic® C – System control for TopVent® C-SYS

Control system for the energy-optimised operation of decentralised Hoval indoor climate systems. Maximum system size per system bus: 1 control zone with up to 6 supply air handling units and 10 recirculation air handling units.

System structure

- Zone control panel, designed as compact cabinet for wall installation, made of coated sheet steel (light grey RAL 7035), 380 × 300 × 210 mm, with:
 - Operating panel
 - Zone controller
 - Fresh air temperature sensor
 - 1 Room temperature sensor (expandable to up to 4 room temperature sensors)
 - Safety relay
 - Electrical cabinet internally pre-wired
- Zone bus: as serial bus for communication with all controllers in the control zone, with robust bus protocol via shielded, twisted bus cable (provided by the client)
- Unit controller: installed in the particular indoor climate unit, works autonomously according to the specifications of the zone controller
- Circuit board with external connections for:
 - Power supply
 - Zone bus
 - Room temperature sensors (max. 4)
 - Fresh air temperature sensor
 - Combination sensor room air quality, temperature and humidity
 - Collective alarm
 - Forced off
 - Heating demand
 - Setpoint heating demand
 - Fault heat supply
 - Cooling demand
 - Fault cold supply
 - External enabling heating/cooling (for automatic changeover)
 - External setting heating/cooling (for manual changeover)
 - Changeover valves heating/cooling
 - External setpoint fresh air ratio
 - Operating selector switch on terminal (digital)
 - Operating selector button on terminal

Functions, standard

- Room temperature control via sequential control of the coils
- Intelligent automatic heating to reach the desired room temperature at the switching time
- 4 adjustable room temperature set values per zone:
 - Cooling protection (lower setpoint in standby)
 - Overheating protection (upper setpoint in standby)
 - Room set value winter
 - Room set value summer

- Destratification mode for even temperature distribution
- Main operating modes of supply air units:
 - REC . Recirculation, infinitely variably adjustment
 - DES.. Destratification
 - SA Supply air, infinitely variably adjustment
 - With Hoval combination sensor (option) also demand-driven control of the fresh air ratio, optional reference variable CO₂ or VOC
 - ST Standby
- Main operating modes of recirculated air units:
 - REC . Recirculation, infinitely variably adjustment
 - DES.. Destratification
 - ST Standby
- Forced heating (construction site heating) can be activated on each device before completion of the overall system (activation by Hoval service technician)
- Control of draught-free air distribution with the Hoval Air-Injector: the discharge direction is adjusted infinitely variably and automatically according to the respective operating condition and the existing temperatures (heating/cooling).

Operation

- Operating panel with LCD display, installed in the door of the zone control panel for visualisation and control of all Hoval indoor climate units registered on the bus

Options for operation

- Operating of the units via building management system via standardised interfaces:
 - BACnet
 - Modbus IP
 - Modbus RTU

Alarms, protection

- Central alarm management with registration of all alarms (timestamp, priority, status) in an alarm list and alarm memory of the last 50 alarms; forwarding via e-mail can be set in the parameters.
- If there is a failure of communication, bus stations, sensor systems or supply media, each part of the system transitions to a protection mode which safeguards operation.
- A maintenance mode implemented in the control algorithm for testing all physical data points and alarms guarantees high reliability.
- Pre-programmed data points retrievable via logger function for 1 year

Options for the zone control panel

- Additional room temperature sensors (max. 3)
- Combination sensor room air quality, temperature and humidity
- Signal for external extract air fan



Options

1 Type code	44
2 Outlet nozzle	46
3 Suspension set	46
4 Air filtration	46
5 Paint finish	47
6 Recirculation silencer	47
7 Acoustic cowl	47
8 Flue gas accessories	48

1 Type code

1.1 TopVent® TG

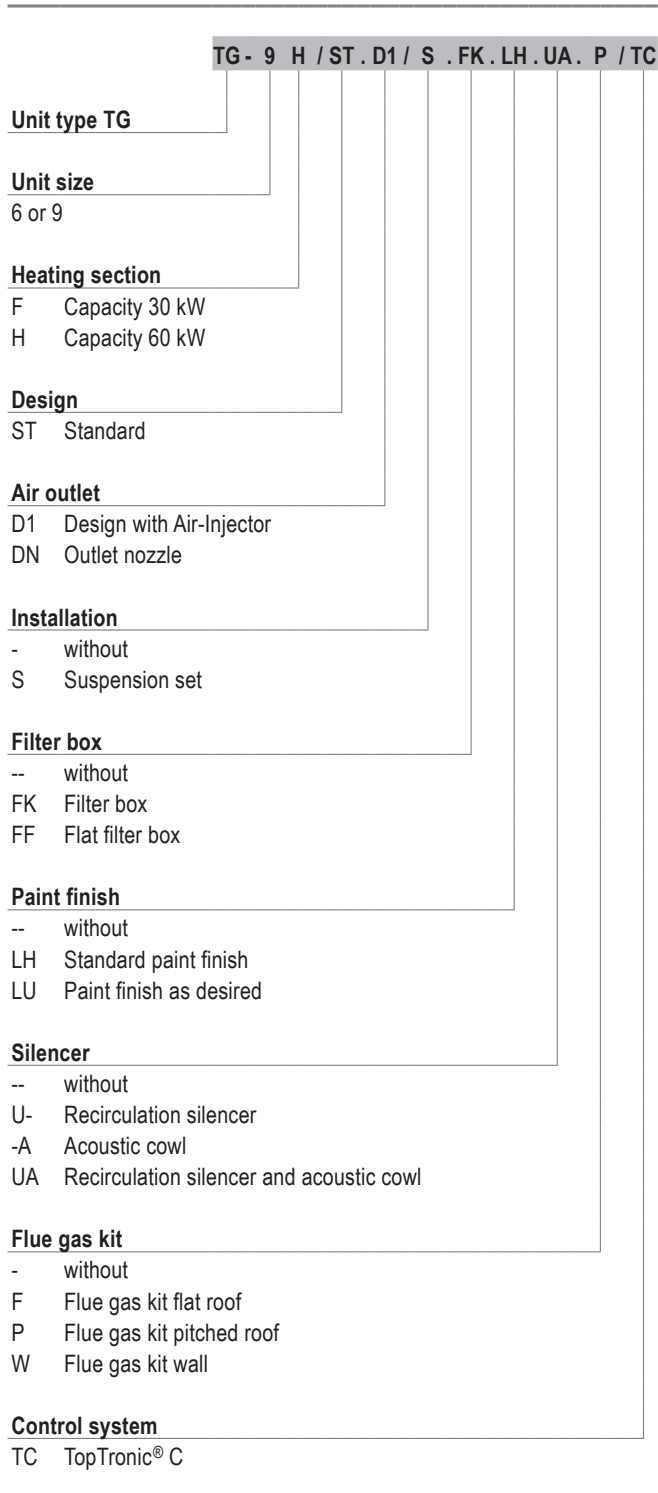

Table E1: TopVent® TG type code

1.2 TopVent® GV

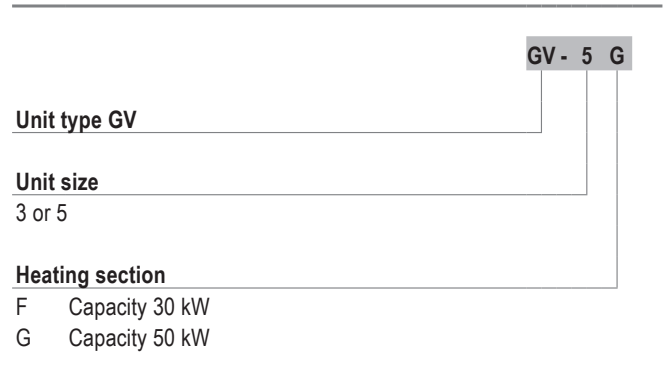

Table E2: TopVent® GV type code

1.3 TopVent® MG

	MG	9	H	/	ST	.	D1	/	S	.	--	.	LH	.	A	.	P	/	TC
Unit type MG																			
Unit size 6 or 9																			
Heating section F Capacity 30 kW H Capacity 60 kW																			
Design ST Standard																			
Air outlet D1 Design with Air-Injector																			
Installation - without S Suspension set																			
Paint finish -- without LH Standard paint finish LU Paint finish as desired																			
Silencer - without A Acoustic cowl																			
Flue gas kit - without F Flue gas kit flat roof P Flue gas kit pitched roof W Flue gas kit wall																			
Control system TC TopTronic® C																			

Table E3: TopVent® MG type code

2 Outlet nozzle

For low-cost recirculation heating the TopVent® TG unit is available with a simple outlet nozzle. The air discharge angle cannot be adjusted. Units with outlet nozzle are well-suited for applications with lower comfort requirements and for large mounting heights (e.g. in high-bay warehouses).

The outlet nozzle replaces the Air-Injector. The external dimensions of the unit remain the same. The weight is reduced:

- Size 6: – 15 kg
- Size 9: – 21 kg

3 Suspension set

For ease of installation of the units, there are suspension sets available (complete with nuts and bolts).

Use	Description
 <p>Ceiling installation TopVent® TG / MG</p>	<ul style="list-style-type: none"> ■ of magnesium zinc sheet ■ height adjustable to a maximum of 1300 mm
 <p>Ceiling installation TopVent® GV</p>	<ul style="list-style-type: none"> ■ of galvanised sheet steel ■ height adjustable to a maximum of 1650 mm
 <p>Wall mounting TopVent® GV</p>	<ul style="list-style-type: none"> ■ of galvanised sheet steel ■ painted black ■ adjustable to the wall separation 400...640 mm (GV-3) 420...560 mm (GV-5)

Fig. E1: Suspension sets

4 Air filtration

For hygiene reasons, Hoval recommends always fitting TopVent® TG units with a filter.

4.1 Filter box

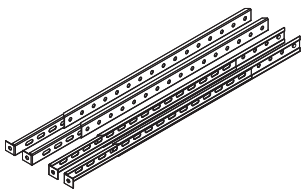
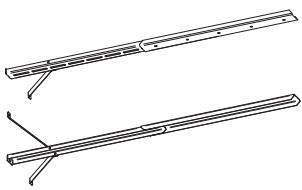
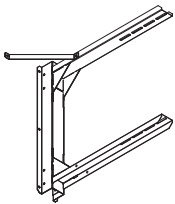
A filter box with 2 bag filters can be installed for the purpose of filtering the recirculation air. The modular construction made of magnesium zinc sheet with 2 sliding doors makes it easy to replace the filters.



Notice

In the planning phase make sure there is enough space in front of the sliding doors so that the filters can be replaced with ease.

A pressure difference control device is installed for automatic monitoring of the filter. It shows when the filters have to be changed.

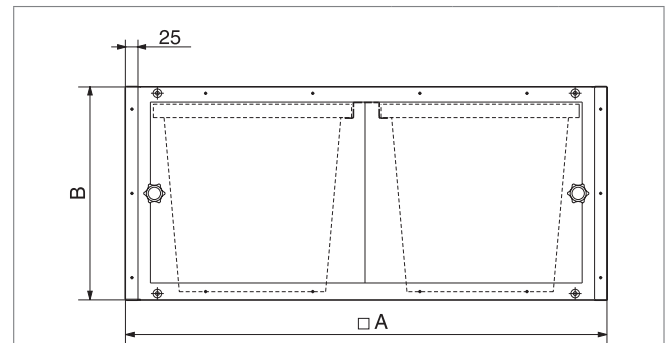

Size		6	9
A	mm	900	1100
B	mm	400	400
Filter class		ISO coarse 60 % (G4)	
Weight	kg	20	24
Factory setting of differential pressure switches	Pa	180	180

Table E4: Filter box technical data



Notice

TopVent® MG supply air units are equipped with a filter box as standard.

4.2 Flat filter box

A flat filter box with 4 pleated cell filters can be installed for the purpose of filtering the recirculation air. A pressure difference control device is installed for automatic monitoring of the filter. It shows when the filters have to be changed.

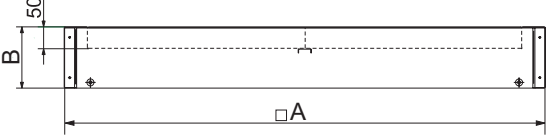

Size		6	9
A	mm	900	1100
B	mm	140	165
Filter class		ISO coarse 60 % (G4)	
Weight	kg	10	12.5
Factory setting of differential pressure switches	Pa	50	50

Table E5: Flat filter box technical data

5 Paint finish

If the customer wishes, the units can be provided with an exterior paint finish. There are 2 possibilities:

- Standard paint finish in Hoval red (RAL 3000)
- Paint finish in desired RAL colour

6 Recirculation silencer

The use of a recirculation silencer for noise reduction is recommended mainly if the TopVent® units are installed under flat, hard ceilings (e.g. made of concrete or sheet steel). The recirculation silencer is mounted on the appliance and thus reduces the sound reflection from the ceiling. Insertion attenuation is 3 dB compared with the total sound power level of each TopVent® unit.

Mount the recirculation units as usual via the 4 fastening points in the heating section (for example, using the optional suspension set).



Caution

Risk of injury from falling parts. The silencer cannot bear the weight of the appliance. Do not locate any suspension points on the silencer.

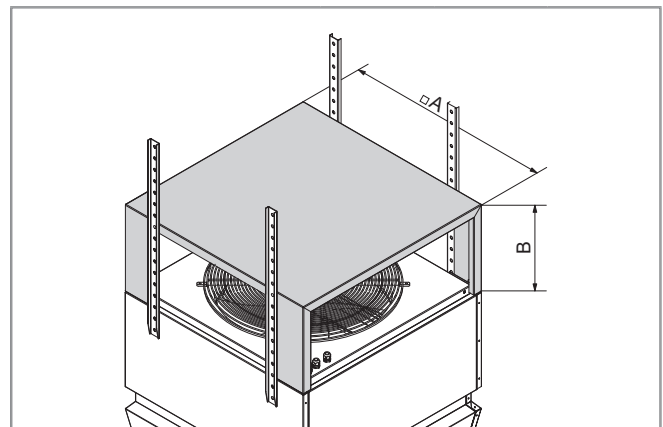

Size		6	9
A	mm	900	1100
B	mm	380	485
Weight	kg	15	20

Table E6: Recirculation silencer dimensions and weights

7 Acoustic cowl

The acoustic cowl reduces the noise level in the room; it is installed in the Air-Injector. This does not change the outside dimensions of the Air-Injector.

Insertion attenuation is 4 dB compared with the total sound power level of each TopVent® unit.

8 Flue gas accessories

8.1 Flue gas kits

For simple, room air independent installation of TopVent® gas units flue gas kits are available. These consist of die-cast aluminium. Components visible from outside are painted in grey (RAL 7021).

There are different versions according to the following criteria:

Flue gas kit flat roof DN 80	Flue gas kit pitched roof DN 80	Flue gas kit wall DN 80
	 <p>Appropriate for roof inclinations between 25° and 45°</p>	
<p>Components:</p> <ul style="list-style-type: none"> ■ Roof feed-through ■ Flat roof flange ■ Flue gas pipe ■ T-piece ■ Condensate cap ■ Elbow bend 90° 	<p>Components:</p> <ul style="list-style-type: none"> ■ Roof feed-through ■ Lead pan with shell ■ Flue gas pipe ■ T-piece ■ Condensate cap ■ Elbow bend 90° 	<p>Components:</p> <ul style="list-style-type: none"> ■ Wall feed-through ■ Flue gas pipe ■ T-piece ■ Condensate cap

Table E7: Flue gas kit dimensions and components (dimensions in mm)



Notice

The installer can shorten the roof feed-through or the wall feed-through (concentric pipe) as appropriate in order to adapt it to the particular conditions required.

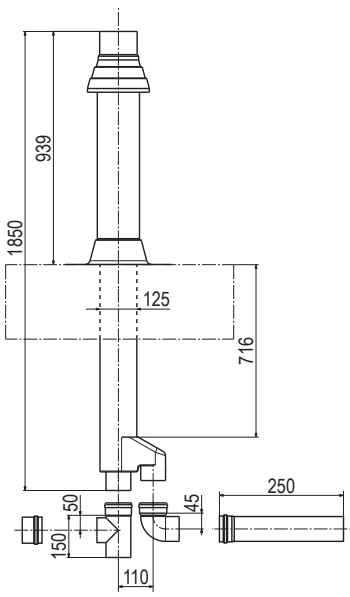
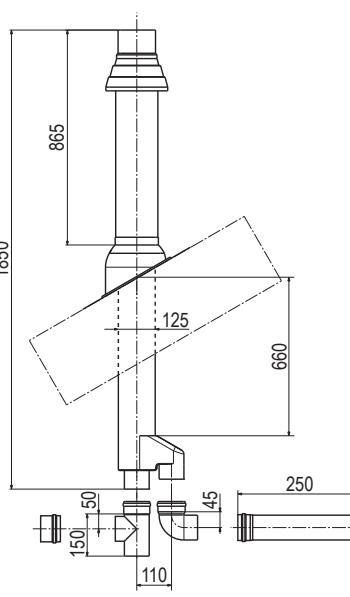
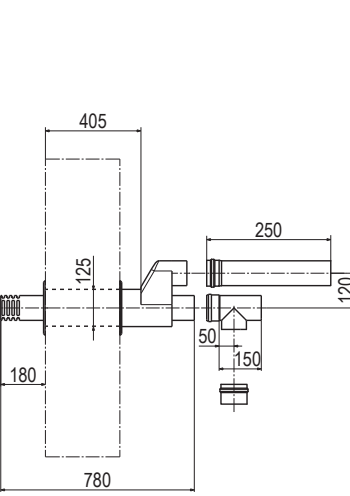
8.2 Individual parts

The following individual parts are also available for the adaptation of the flue gas kit to the particular situation:

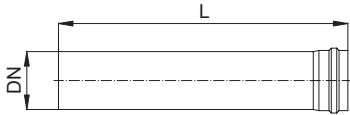
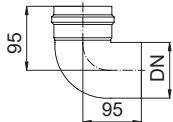
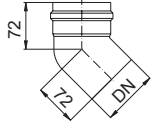
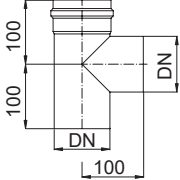
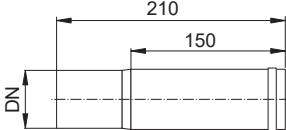
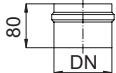
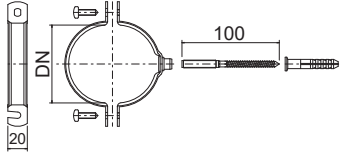
<p>Flue gas pipe ¹⁾</p>	<p>L = 250 / 500 / 1000</p> 
<p>Elbow bend 90° ¹⁾</p>	
<p>Elbow bend 45° ¹⁾</p>	
<p>T-piece ¹⁾</p>	
<p>Length adjustment piece</p>	
<p>Condensate cap</p>	
<p>Pipe clamp</p>	

¹⁾ Insertion depth of pipe collar = 50 mm

Table E8: Individual components of flue gas accessories (dimensions in mm, DN 80)



Transport and installation

1 Installation	52
2 Flue gas evacuation	54
3 Gas connection	55
4 Electrical installation	55

1 Installation

1.1 Preparation

The following guidelines are important when preparing for installation:

- The scope of delivery includes:
 - TopVent® unit, delivered on a pallet
 - Accessories (flue gas duct, installation material, temperature sensors)
 - Optional components
- Make sure that a lifting platform is available.
- Use the optionally available suspension set or flat irons, perforated irons, angle profiles, steel cables or similar for mounting.

1.2 Positioning

- Comply with the minimum and maximum distances.
- Only secure the unit to ceilings or walls with sufficient load-bearing capacity.
- The surface temperature of the flue gas pipes amounts to 200 °C. Please observe the regulations of the responsible fire protection authorities.
- Position the unit in such a way that no one is endangered by flue gas and radiant heat and no fires can break out.
- All air inlet and air outlet openings must be freely accessible. The supply air jet must be free to spread out unhindered.
- The access panels in the unit must be freely accessible.
- The unit must be accessible for maintenance work. The connecting lines must be able to be dismantled.
- Make sure that supply air units draw in fresh air via the fresh air duct.

TopVent® GV – vertical air flow

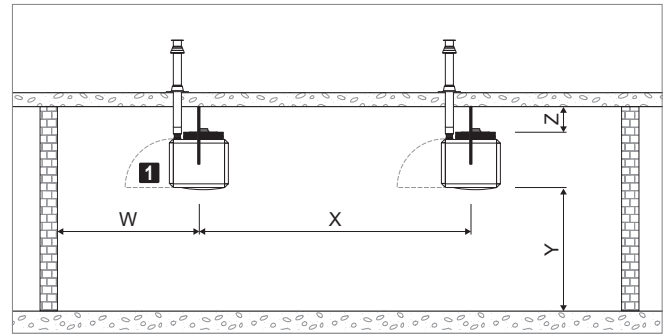

1 Free space to open inspection door

Unit type			GV-3	GV-5
Distance from ceiling Z	min.	m	0.3	0.3
	max.	m	4.0	4.0
Mounting height Y	min.	m	5.0	6.0
	max.	m	7.0	10.0
Distance from wall W	min.	m	3.5	5.0
	max.	m	12.0	16.0
Unit clearance X	min.	m	7.0	10.0
	max.	m		

Table F1: TopVent® GV minimum and maximum distances for vertical air flow (ceiling mounting)

TopVent® GV – horizontal air flow

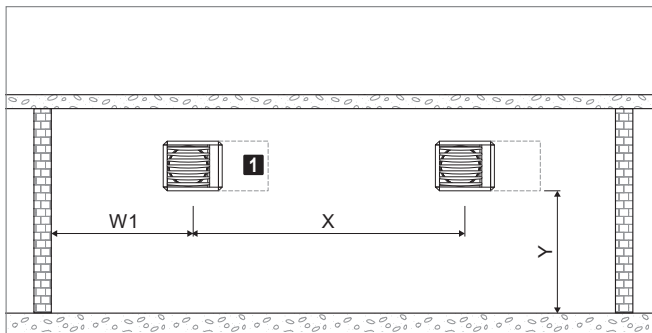

1 Free space to open inspection door

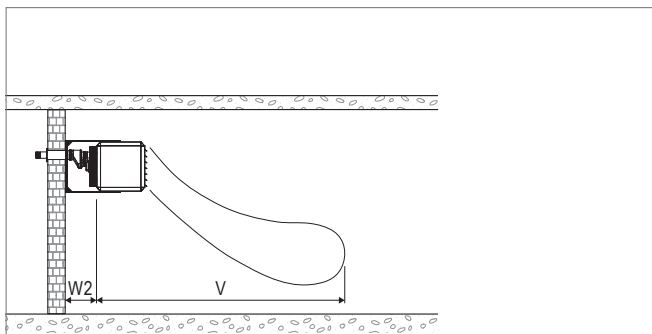

Unit type			GV-3	GV-5
Mounting height Y	min.	m	1.7	1.7
	max.	m	5.0	6.0
Distance from wall W1	max.	m	7.0	10.0
	min.	m	3.5	5.0
Unit clearance X	max.	m	12.0	16.0
	min.	m	7.0	10.0
Distance from wall W2 ¹⁾	min.	m	0.3	0.3
Reach V		m	23.0	28.8

¹⁾ The effective distance from wall depends on the method of flue gas evacuation chosen.

Table F2: TopVent® GV minimum and maximum distances for horizontal air flow (wall mounting)

TopVent® TG / MG

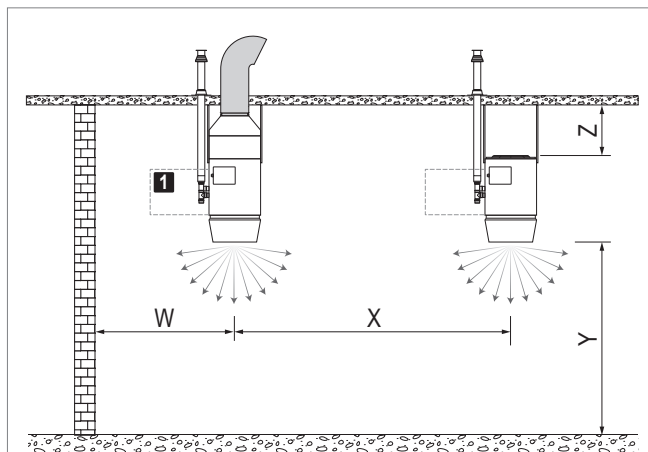

1 Clearance of approx. 1.5 m for maintenance work

Unit type	Size	TG		MG		
		6	9	6	9	
Distance from ceiling Z	min.	m	0.3	0.4	0.3	0.4
	max. ¹⁾	m	Approx. 9...25			
Mounting height Y	min.	m	4	5	4	5
	Applications with higher comfort requirements					
■ Distance from wall W	max.	m	13	16	13	16
	min.	m	6	8	6	8
■ Unit clearance X	max.	m	26	36	26	36
	min.	m	13	16	13	16
Applications with low comfort requirements						
■ Distance from wall W	max.	m	13	20	–	–
	min.	m	6	8	–	–
■ Unit clearance X	max.	m	27	40	–	–
	min.	m	13	16	–	–

¹⁾ The maximum mounting height varies depending on the boundary conditions (for values, see table of heat outputs or calculation with the 'HK-Select' selection program)

Table F3: TopVent® TG / MG minimum and maximum distances

1.3 Unit installation

Proceed as follows to position the unit:

- Transport the unit to the installation site and rotate it to the correct position.
- Fasten the unit to the designated suspension points.
- Connect supply air units to a fresh air duct via a canvas connection and connect both flanges with an earth wire.

2 Flue gas evacuation

- In all cases, use only the original flue gas accessories approved for use with the units for the installation. Do not combine systems from different manufacturers.
- Observe national / local regulations when planning the flue gas evacuation and the combustion air supply. From an early stage, coordinate the installation with the responsible district chimney sweep authorities and obtain the necessary authorisation from the local building authority.
- Provide suitable openings for the roof and wall feed-through of the flue gas ducts (for the dimensions of the flue gas accessories, see Part G 'Options').
- Use flue pipes with the same diameter as the combustion air and flue gas connections on the unit.
- Observe the maximum length of the flue gas duct.
- Condensation may form in horizontal flue gas ducts > 4 m long or in ducts through cool rooms:
 - Insulate the pipes using temperature-resistant, non-flammable material.
 - Insert a condensate cap.
- Install horizontal flue gas ducts with at least 3° inclination (50 mm/m) towards the unit so that condensate can flow to the air heater.
- The surface temperature of the flue gas pipes amounts to 200°C. During the planning process, please observe the regulations of the responsible fire protection authorities.
- For the flue gas path test, Hoval recommends installing an inspection T-piece (included in the flue gas kit).
- For all diversions, install an inspection T-piece in the flue gas pipe as well.
- In some countries, an annual inspection and emission measured by the responsible authorities is legally required. For this purpose, measurement openings have been provided in the exhaust spout and the access panel.
- In some countries (e.g. in Germany), an emission measurement from the roof is also permissible. For this purpose, provide measurement openings in the flue gas pipe and in the combustion air pipe directly above the roof (on-site installation in 3-shell pipe).

Room air-dependent installation

- The units can be installed as room air dependent (Type B₂₃) or room air independent (Type C₁₃, C₃₃) appliances.
- For room air dependent operation the combustion air is taken directly from the room in which the unit is installed. Ensure the room is sufficiently ventilated and that the combustion air is free from pollutants and aggressive substances (halogens such as chlorides, fluorides, etc.).
- In case of room air dependent installation (Type B₂₃), close off the combustion air connection using a protective screen.

3 Gas connection



Caution

Risk of injury from incorrect handling. Gas connection must be carried out by trained specialists only!

Please note the following:

- The fuel used is natural gas. Check the type of gas the unit is set to work with and, if necessary, have Hoval Customer Service reset the unit to the type of gas supplied locally.
- During operation of the unit, the required quantity of gas and the necessary pressure of gas must be present constantly.
- Connect the gas supply line with appropriate bolted joints which can be loosened, tension-free and vibration-free.
- The connection of the unit to the gas supply line must be gas-tight.
- Install a gas pressure regulator and a gas shut-off valve in the gas supply line immediately upstream of the unit, as well as other components required by local regulations, such as gas filter, gas pressure regulator, pressure gauge with push-button tap, etc. (not included in the scope of delivery).

4 Electrical installation

- The electrical installation must only be carried out by a qualified electrician.
- Observe the relevant regulations (e.g. EN 60204-1).
- Choose the dimensions of the cable cross sections in line with the applicable regulations.
- Route signal and bus lines separately from mains cables.
- Make sure the lightning protection system for the units or for the entire building is planned and carried out by professionals.
- Provide overload protection equipment on site in the mains connection line of the zone control panel.
- Carry out the electrical installation according to the wiring diagram:
 - Power supply for TopVent®
 - Zone bus based on system layout
 - Signal lines

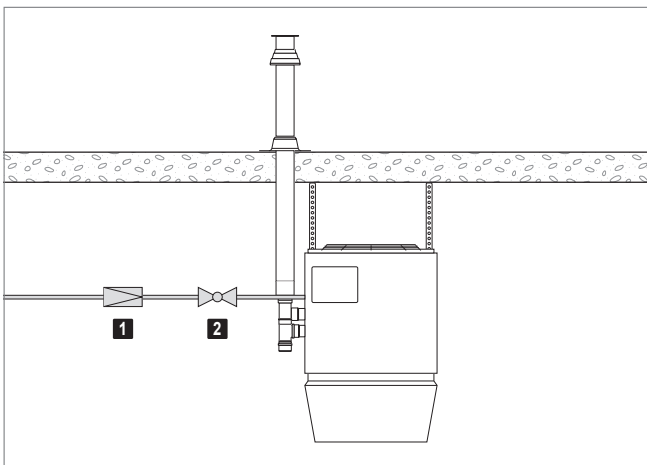

1 Gas pressure regulator (20...50 mbar)

Recommended settings:

- Natural gas G20 20 mbar
- Natural gas G25 25 mbar

2 Cut-off-valve

Fig. F1: Gas pressure regulator and cut-off valve in the gas supply line

TopVent® TG / GV / MG with TopTronic® C

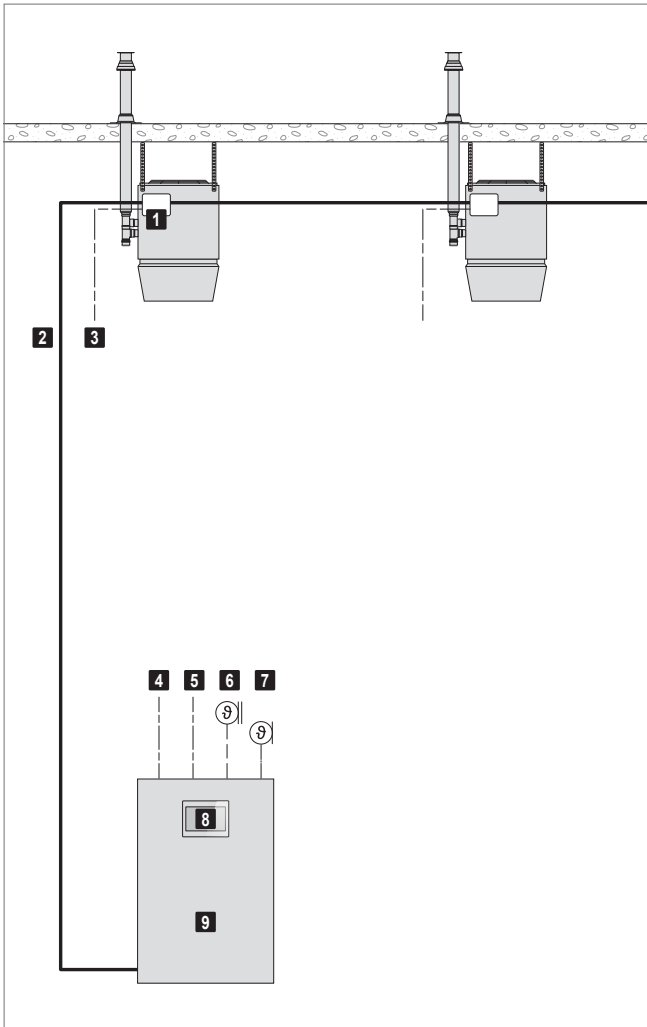

- 1 Unit control box
- 2 Zone bus
- 3 Power supply for TopVent®
- 4 Power supply for control panel
- 5 Collective alarm
- 6 Fresh air temperature sensor
- 7 Room temperature sensor
- 8 System operator terminal
- 9 Zone control panel

Fig. F2: TopTronic® C connection diagram

TopVent® GV with TempTronic MTC

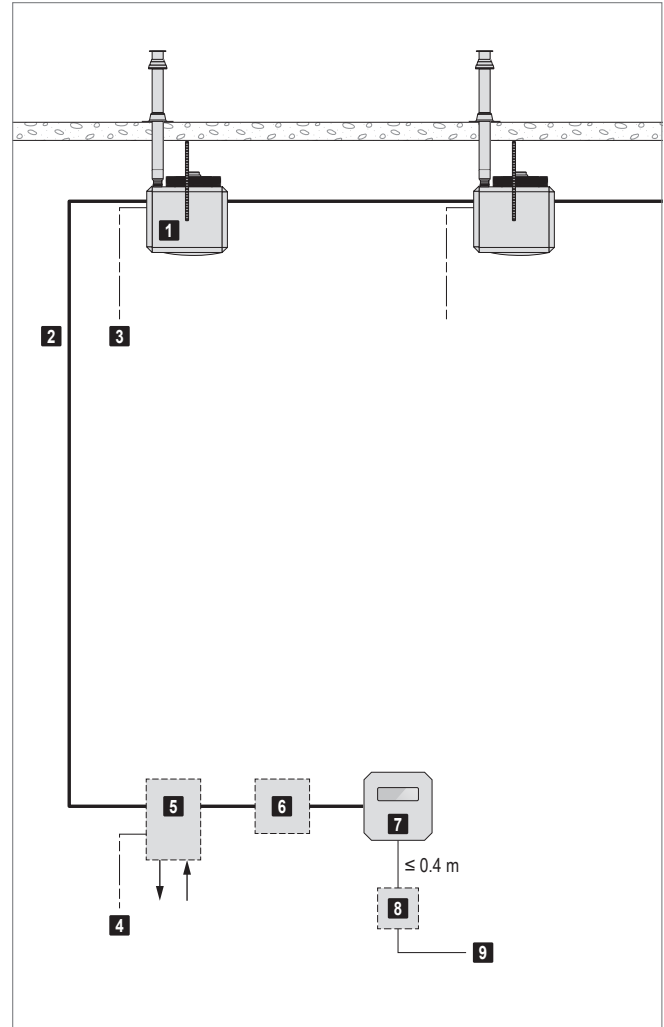

- 1 TopVent® GV (max. 8)
- 2 System bus
- 3 Power supply for TopVent® GV
- 4 Power supply for option module
- 5 Option module
- 6 External room temperature sensor
- 7 TempTronic MTC
- 8 Relay (field-supplied)
- 9 External switching

Fig. F3: TempTronic MTC connection diagram

4.1 Cable list for on-site connections – TopTronic® C

Component	Designation	Voltage	Cable	Comments	Start	Target	
TopTronic® C System control	Power supply	3 × 400 VAC	NYM-J 5 × ... mm ²		On-site	Zone control panel	
		1 × 230 VAC	NYM-J 3 × ... mm ²		On-site	Zone control panel	
Zone control panel	Zone bus		J-Y(ST)Y 2 × 2 × 0.8 mm	max. 500 m length	Zone control panel	Hoval units	
	System bus		Ethernet ≥ CAT 5	For connecting several zone control panels	Zone control panel	Further zone control panel	
	Integration into the building management system		Ethernet ≥ CAT 5	BACnet, Modbus IP	Zone control panel	On-site (BMS)	
			J-Y(ST)Y 2 × 2 × 0.8 mm	Modbus RTU	Zone control panel	On-site (BMS)	
	Room temperature sensor		J-Y(ST)Y 2 × 2 × 0.8 mm	max. 250 m	Zone control panel	Sensors	
	Additional room temperature sensors		J-Y(ST)Y 2 × 2 × 0.8 mm	max. 250 m	Zone control panel	Sensors	
	Combination sensor room air quality, temperature and humidity		J-Y(ST)Y 4 × 2 × 0.8 mm	max. 250 m	Zone control panel	Sensors	
	Fresh air temperature sensor		J-Y(ST)Y 2 × 2 × 0.8 mm	max. 250 m	Zone control panel	Sensors	
	Combination sensor fresh air temperature and humidity		J-Y(ST)Y 2 × 2 × 0.8 mm	max. 250 m	Zone control panel	Sensors	
	Collective alarm	Volt-free max. 230 VAC max. 24 VDC	NYM-O 2 × 1.5 mm ²	max. 3 A max. 2 A		Zone control panel	On-site
	Power supply for units		3 × 400 VAC	NYM-J 5 × 4.0 mm ² (min.)	RoofVent® RG	Zone control panel or on-site	Hoval units
			3 × 400 VAC	NYM-J 5 × 1.5 mm ² (min.)	TopVent® TG / MG		
			1 × 230 VAC	NYM-J 3 × 1.5 mm ² (min.)	TopVent® GV		
	System operator terminal (if external)		24 VDC	NYM-J 3 × 1.5 mm ²	Power supply 0.42 A	Zone control panel	System operator terminal
				Ethernet ≥ CAT 5	Communication	Zone control panel	System operator terminal
	Zone operator terminal (if external)	24 VAC	J-Y(ST)Y 4 × 2 × 0.8 mm	Power supply, 1 A fusing, max. 250 m length	Zone control panel	Zone operator terminal	
	External sensor values	0-10 VDC	J-Y(ST)Y 2 × 2 × 0.8 mm		On-site	Zone control panel	
	External set values	0-10 VDC	J-Y(ST)Y 2 × 2 × 0.8 mm		On-site	Zone control panel	
	Load shedding input	24 VAC	NYM-O 2 × 1.5 mm ²	max. 1 A	On-site	Zone control panel	
Operating selector switch on terminal (analogue)	0-10 VDC	J-Y(ST)Y 2 × 2 × 0.8 mm		On-site (switch)	Zone control panel		
Operating selector switch on terminal (digital)	0-10 VDC	J-Y(ST)Y 6 × 2 × 0.8 mm		On-site (switch)	Zone control panel		
Operating selector button on terminal	24 VAC	J-Y(ST)Y 6 × 2 × 0.8 mm		On-site (button)	Zone control panel		
Forced off	24 VAC	NYM-O 2 × 1.5 mm ²	max. 1 A	On-site	Zone control panel		

Component	Designation	Voltage	Cable	Comments	Start	Target	
TopTronic® C System control for TopVent® (C-SYS) Zone control panel	Power supply	1 × 230 VAC	NYM-J 3 × 1.5 mm ²		On-site	Zone control panel	
	Zone bus		J-Y(ST)Y 2 × 2 × 0.8 mm	max. 500 m length	Zone control panel	Hoval units	
	Integration into the building management system		Ethernet	≥ CAT 5	BACnet, Modbus IP	Zone control panel	On-site (BMS)
			J-Y(ST)Y 2 × 2 × 0.8 mm		Modbus RTU	Zone control panel	On-site (BMS)
	Room temperature sensor		J-Y(ST)Y 2 × 2 × 0.8 mm	max. 250 m	Zone control panel	Sensors	
	Additional room temperature sensors		J-Y(ST)Y 2 × 2 × 0.8 mm	max. 250 m	Zone control panel	Sensors	
	Combination sensor room air quality, temperature and humidity		J-Y(ST)Y 4 × 2 × 0.8 mm	max. 250 m	Zone control panel	Sensors	
	Fresh air temperature sensor		J-Y(ST)Y 2 × 2 × 0.8 mm	max. 250 m	Zone control panel	Sensors	
	Collective alarm	Volt-free max. 250 VAC max. 24 VDC	NYM-O 2 × 1.5 mm ²	max. 8 A max. 2 A	Zone control panel	On-site	
	External setpoint fresh air ratio	0-10 VDC	J-Y(ST)Y 2 × 2 × 0.8 mm		On-site	Zone control panel	
	Operating selector switch on terminal (digital)	0-10 VDC	J-Y(ST)Y 6 × 2 × 0.8 mm		On-site (switch)	Zone control panel	
	Operating selector button on terminal	24 VAC	J-Y(ST)Y 6 × 2 × 0.8 mm		On-site (button)	Zone control panel	
	Forced off	24 VAC	NYM-O 2 × 1.5 mm ²	max. 1 A	On-site	Zone control panel	
TopVent® TG TopVent® MG	Power supply	3 × 400 VAC	NYM-J 5 × 1.5 mm ² (min.)	min. 7 m length	Zone control panel or on-site	TopVent® unit	
	Zone bus		J-Y(ST)Y 2 × 2 × 0.8 mm	max. 500 m length	Zone control panel	TopVent® unit	
	Forced off	24 VAC	NYM-O 2 × 1.5 mm ²	max. 1 A for TopVent® MG	On-site	TopVent® unit	
TopVent® GV	Power supply	1 × 230 VAC	NYM-J 3 × 1.5 mm ² (min.)	max. 200 m length	Zone control panel or on-site	TopVent® unit	
	Zone bus		J-Y(ST)Y 2 × 2 × 0.8 mm	max. 500 m length	Zone control panel	TopVent® unit	

Table F4: Cable list for on-site connections – TopTronic® C

4.2 Cable list for on-site connections – TempTronic MTC

Component	Designation	Voltage	Cable	Comments	Start	Target
TempTronic MTC Controller	System bus		J-Y(ST)Y 1 × 2 × 0.8 mm	shielded, twisted, max. 200 m length	Hoval controller	Hoval units
	External switching	1 × 230 VAC	NYM 3 × 1.5 mm ²	via on-site relay, max 3 A	Relay (on-site)	Hoval controller
TempTronic MTC Option module	Power supply	1 × 230 VAC	NYM 3 × 1.5 mm ² (min.)		On-site	Option module
	Collective alarm	1 × 230 VAC	NYM-O 2 × 1.5 mm ²		Option module	On-site
	Operating signal display	24 VAC	NYM-O 2 × 1.5 mm ²	max. 4 A	Option module	On-site
	Alarm reset signal	24 VAC	NYM-O 2 × 1.5 mm ²	max. 1 A	On-site	Option module
	Control of the fan	0-10 VDC	J-Y(ST)Y 2 × 2 × 0.8 mm		On-site	Option module
	Control of the burner	0-10 VDC	J-Y(ST)Y 2 × 2 × 0.8 mm		On-site	Option module
	Signal for maximum output	24 VAC	NYM-O 2 × 1.5 mm ²	max. 1 A	On-site	Option module
	Signal for minimum output	24 VAC	NYM-O 2 × 1.5 mm ²	max. 1 A	On-site	Option module
	Signal for summer ventilation	24 VAC	NYM-O 2 × 1.5 mm ²	max. 1 A	On-site	Option module
TopVent® GV	Power supply	1 × 230 VAC	NYM 3 × 1.5 mm ² (min.)	max. 200 m length	On-site	TopVent® unit
	System bus		J-Y(ST)Y 1 × 2 × 0.8 mm	shielded, twisted, max. 200 m length	Hoval controller	TopVent® unit

Table F5: Cable list for on-site connections – TempTronic MTC



System design

1 Design example. 62

2 Maintenance schedule 65

3 Checklist for project discussions 66



G

1 Design example



Notice

Use the 'HK-Select' program to design Hoval Indoor Climate Systems. You can download it free of charge on the Internet.

1.1 Applications with higher comfort requirements (e.g. production halls, assembly halls, sports halls)

Design data	Example
<ul style="list-style-type: none"> ■ Geometry of the room ■ Internal heat gains ■ People in the room ■ Heating with decentralised gas-fired heat generation ■ Improvement of air quality, fresh air supply for the people in the room (fresh air flow rate per person = 30 m³/h) 	<p>50 × 60 × 12 m 28 kW 20 people</p>
<p>Design conditions heating:</p> <ul style="list-style-type: none"> ■ Fabric heat losses ■ Fresh air temperature ■ Room temperature ■ Extract air temperature 	<p>350 kW - 15 °C 18 °C 20 °C</p>
<p>Fresh air supply</p> <ul style="list-style-type: none"> ■ Required fresh air flow rate in total: ■ Fresh air ratio of supply air units: max. 10 % of the nominal air flow rate <p><i>The fresh air ratio can be adjusted from 0...100 %. Where EU Regulation 1253/2014 applies, it must be restricted to max. 10 % in the design conditions.</i></p> <ul style="list-style-type: none"> ■ Calculate the required number of supply air units from the nominal air flow rate. 	<p>20 × 30 = 600 m³/h</p> <p>Size 6: max. 700 m³/h fresh air Size 9: max. 1100 m³/h fresh air</p> <p>→ 1 TopVent® MG unit</p>
<p>Mounting height</p> <ul style="list-style-type: none"> ■ Calculate the actual mounting height (= distance between the floor and the bottom edge of the units). <p>$Y = \text{Hall height} - \text{distance from ceiling} - \text{unit height}$</p> <ul style="list-style-type: none"> ■ Compare the actual mounting height with the minimum and maximum mounting height (see Table F3 on page 53 and HK-Select). 	<p><u>Supply air units:</u> Size 6 → OK Size 9 → OK</p> <p><u>Recirculation units:</u> Size 6 → OK Size 9 → OK</p>
<p>Required performance for covering fabric heat losses</p> <ul style="list-style-type: none"> ■ Required heat output for coverage of fabric heat losses in total: <p>$Q_{H_req} = \text{Fabric heat losses} - \text{internal heat loads}$</p>	<p>350 – 28 = 322 kW</p>

Required heat output of recirculation units

- Determine the required heat output of the recirculation units based on the output of the supply air unit.

$$Q_{H_Recirculation} = Q_{H_req} - Q_{H_Supply\ air}$$

For the supply air unit, take into account only the share of capacity that is used for coverage of fabric heat losses (separately shown in HK-Select).

Type	Q _{H_Supply air}	Q _{H_Recirculation}
MG-6	21.1	322 – 21.1 = 300.9
MG-9	49.0	322 – 49.0 = 273.0

(values in kW)

Minimum number of recirculation units

- Determine the minimum number of recirculation units depending on the available supply air units. Take into account the following criteria:
 - Floor area covered
 - Heat output
 - Unit clearances

Supply air unit	Recirculation units	Required number of recirculation units			Minimum number of recirculation units
		Floor area covered	Heat output	Unit clearances	
1 unit MG-6	TG-6	4	11	6	11
	TG-9	2	5	6	6
1 unit MG-9	TG-6	3	10	4	10
	TG-9	2	5	4	5

- Choose the final solution from the remaining possibilities, depending on the geometry of the hall and the costs.

1.2 Applications with low comfort requirements
(e.g. warehouses, logistics centres)

Design data	Example									
<ul style="list-style-type: none"> ■ Geometry of the room ■ Heating with decentralised gas-fired heat generation 	181 × 105 × 12 m									
Design conditions heating: <ul style="list-style-type: none"> ■ Fabric heat losses ■ Fresh air temperature ■ Room temperature ■ Extract air temperature 	723 kW - 15 °C 15 °C 18 °C									
Mounting height <ul style="list-style-type: none"> ■ Calculate the actual mounting height (= distance between the floor and the bottom edge of the units). $Y = \text{Hall height} - \text{distance from ceiling} - \text{unit height}$ ■ Compare the actual mounting height with the minimum and maximum mounting height (see Table F3 on page 53 and HK-Select). 	Recirculation units: Size 6 → OK Size 9 → OK									
Required number of recirculation units <ul style="list-style-type: none"> ■ Determine the required number of recirculation units based on the heat output. $n = \text{Fabric heat losses} : \text{heat output per unit}$ ■ Choose the final solution from the remaining possibilities, depending on the geometry of the hall and the costs. 	<table border="1" style="width: 100%; border-collapse: collapse; text-align: center;"> <thead> <tr> <th style="width: 30%;">Type</th> <th style="width: 30%;">kW</th> <th style="width: 40%;">Quantity</th> </tr> </thead> <tbody> <tr> <td>TG-6</td> <td>723 : 28.9</td> <td>26</td> </tr> <tr> <td>TG-9</td> <td>723 : 61.2</td> <td>12</td> </tr> </tbody> </table>	Type	kW	Quantity	TG-6	723 : 28.9	26	TG-9	723 : 61.2	12
Type	kW	Quantity								
TG-6	723 : 28.9	26								
TG-9	723 : 61.2	12								

2 Maintenance schedule

Activity	Procedure	Interval
Clean unit	<ul style="list-style-type: none"> ■ Clean inside of unit with vacuum cleaner. ■ Clean fan with vacuum cleaner or plastic brush. ■ Clean Air-Injector with vacuum cleaner or plastic brush. (TopVent® TG / MG) 	1 × annually
Functional check	<ul style="list-style-type: none"> ■ Check function of the fan. ■ Check function of the Air-Injector. (TopVent® TG / MG) ■ Check function of the control system. 	1 × annually
Heat exchanger and burner	<ul style="list-style-type: none"> ■ Dismantle connecting lines. ■ Loosen screws on the flange of the gas module and pull out gas module. ■ Visual inspection of the heat exchanger outside ■ Clean heat exchanger with plastic brush (do not use steel brush). <div style="border: 1px solid black; padding: 5px; margin: 10px 0;">  <p>Caution Fire hazard due to overheating. Dust build-up on the heat exchanger may lead to overheating and fire. It is essential to thoroughly clean the heat exchanger.</p> </div> <ul style="list-style-type: none"> ■ Dismantle burner and gas blower by loosening the hexagon socket screws on the burner flange. ■ Visual inspection of the burner ■ Check ignition and ionisation electrode. If necessary, carefully clean with fine sand-paper and readjust. ■ Replace burner flange in the event of corrosion or material fatigue. ■ Visual inspection of the heat exchanger inside, clean where necessary. ■ Reinstall burner and gas blower; use new seals for this. ■ Reinstall connecting lines. 	1 × annually
Flue gas path test	<ul style="list-style-type: none"> ■ Visual inspection of the installed components ■ Remove condensate cap on all inspection T-pieces and clean flue gas pipe on the inside as needed. 	1 × annually
Emission measurement	<ul style="list-style-type: none"> ■ Check setting of the gas control valve and readjust where necessary. 	1 × annually
Filter change (TopVent® TG / MG)	<ul style="list-style-type: none"> ■ Renew air filter. 	When the filter alarm is displayed, at least annually

Table G1: Maintenance schedule

Project

Project No.

Date

Name

Function

Address

Tel.

Fax

E-mail

Information about the hall

Application

Type

Insulation

Length

Width

Height

Is the roof strong enough?

yes no

Are there window areas?

yes no

Percentage?

Is there a crane?

yes no

Height?

Is there enough space for installation and servicing?

yes no

Are there any voluminous installations or machines?

yes no

Are pollutants present?

yes no

Which?

– If yes, are they heavier than air?

yes no

Is oil contained in the extract air?

yes no

Is dust present?

yes no

Dust level?

Is there high humidity?

yes no

How much?

Are local machine extractions required?

yes no

Are any conditions imposed by public authorities?

yes no

Which?

Are sound level requirements to be fulfilled?

yes no

Which?

Design data

Internal heat gains (machines, ...) kW

Heating and cooling

Unit size

Control zones

Design conditions heating

■ Standard outside temperature °C

■ Room temperature °C

■ Extract air temperature °C

■ Fabric heat losses kW

Design conditions cooling

■ Standard outside temperature °C

■ Room temperature and humidity °C %

■ Extract air temperature °C

■ Transmission sensible gains kW

Further information



Hoval quality.
You can count on us.

Hoval is one of the leading international companies for heating and indoor climate solutions. Drawing on more than 75 years of experience and benefiting from a close-knit team culture, the Hoval Group delivers exciting solutions and develops technically superior products. This leadership role requires a sense of responsibility for energy and the environment, which is expressed in an intelligent combination of different heating technologies and customised indoor climate solutions.

Hoval also provides personal consultations and comprehensive customer service. With around 2500 employees in 15 companies around the world, Hoval sees itself not as a conglomerate, but as a large family that thinks and acts globally.

Hoval heating and indoor climate solutions are currently exported to more than 50 countries.

Responsibility for energy and environment

Your Hoval partner



Thermotrade Kft.

H-2112 Veresegyház, Szadai u. 13.

+36 28 588 810

thermotrade@hoval.hu

www.thermotrade.hu